

Installation Manual

ENFORCER[®]

PD-5PAQ



Access Control Power Distribution Board

Features:

- Five individually PTC-fused outputs
- Each output will operate in both fail-safe and fail secure modes
- Output fuses rated 1.1 Amps
- Individual LED status indicator for each output, power input, and trigger.
- For 12VDC or 24VDC operation.
- Power failure supervision relay (3 Amps @ 24VDC)
- Auxiliary supervision relay (3 Amps @ 24VDC)
- Equipped with dry and wet trigger inputs.
- Dimensions - 3⁹/₁₆" x 5⁵/₁₆" x 1¹/₁₆" (90 x 135 x 27 mm)

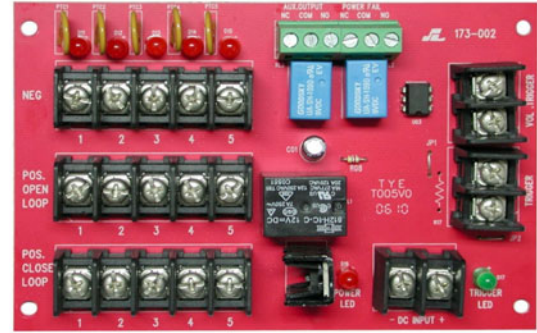

Compatible with the following ENFORCER power supplies
EAP-5D1MQ – 5 Amp Access Control Power Supply/Charger Module
EAP-5D1Q – 5 Amp Access Control Power Supply with metal enclosure

What it is:

This 5-output power distribution board centralizes the power sources for access control electronic locking devices, such as electromagnetic locks, sheer locks, electric door strikes, deadbolt locks, and so on. It provides a separate fuse for each output so that problems with one device may be isolated from the other devices. Each output operates in both fail-safe and fail-secure modes. The board includes wet and dry trigger inputs for emergency door activation such as for releasing emergency exit doors. It is also equipped with power failure supervision relays and auxiliary supervision relays.

Installation:

1. Mount the PC board in the desired location or enclosure. It must be easily accessible for future servicing.
2. Connect the output wires of the 12VDC or 24VDC power supply to the PC board's terminals marked "DC INPUT" as required, see Fig.8.
NOTE: Correct polarity must be observed.
3. Connect the power input wires of the access control devices or accessories to the PC board, see Fig.8. Observe correct polarity. For fail-secure devices, connect positive to terminals marked "POS. OPEN LOOP" and negative to terminals marked "NEG." For fail-safe devices, connect positive to terminals marked "POS. CLOSE LOOP" and negative to terminals marked "NEG."
NOTE: For best results and to minimize voltage drop, these wires should be a minimum of 18-gauge in thickness.
4. Connect a visual or audio indicator device (such as siren or strobe light) to the "POWER FAIL" supervision relay and "Auxiliary output" relay if needed, see Fig.8. Use between 22AWG to 18AWG wire size.
5. Trigger the power distribution board either from a wet and or dry contact switch from the control station by following the connection diagrams shown on Fig. 2~7. See Table 1 on how trigger input function works.

IMPORTANT NOTE: If the "TRIGGER" terminal block function will not be used, then a 2.2KΩ resistor must always be connected to the "TRIGGER" terminal block as shown in Fig. 1.

Fig. 1 – Wiring diagram when "Trigger" terminal will not going to be used.

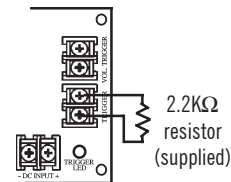

Fig. 2 – Momentary trigger wiring diagram for wet and / or dry N.C. switch.

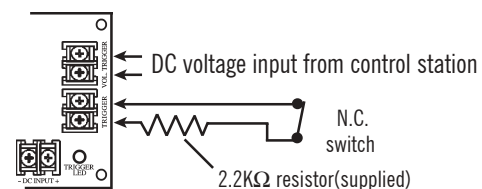

Fig. 3 – Momentary trigger wiring diagram for wet and / or dry N.O. switch.

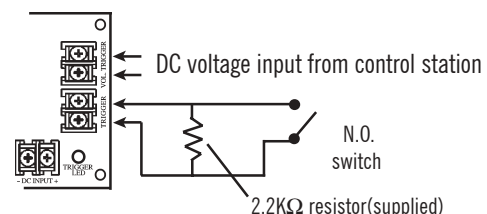

Fig. 4 – Latch trigger wiring diagram for wet and / or dry N.O. switch

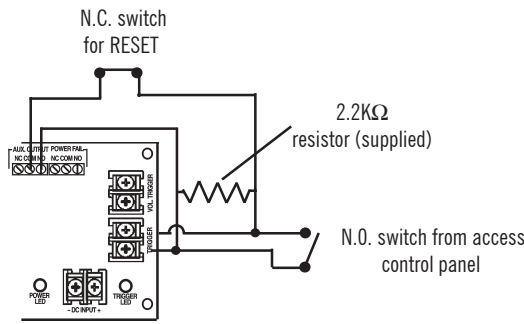

Fig. 5 – Latch trigger wiring diagram for wet and / or dry N.C. switch

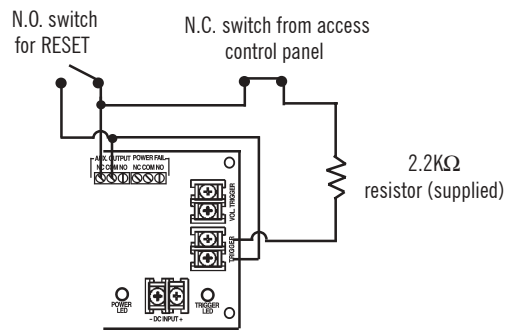

Fig. 6 – Multiple PD-5PAQ momentary trigger wiring diagram for wet and / or dry N.O. switch.

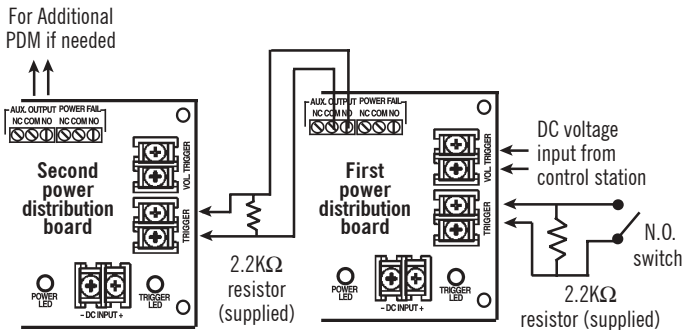

Fig. 7 – Multiple PD-5PAQ momentary trigger wiring diagram for wet and / or dry N.C. switch.

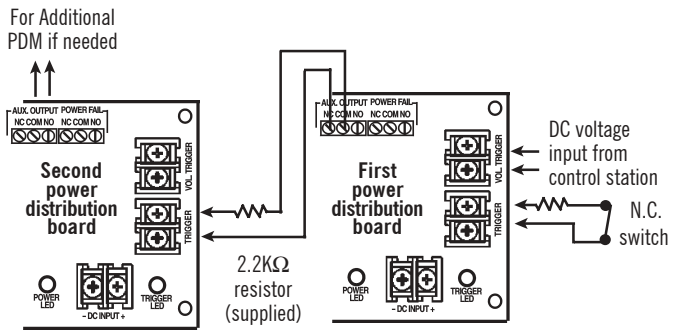

Fig. 8 – Wiring diagram.

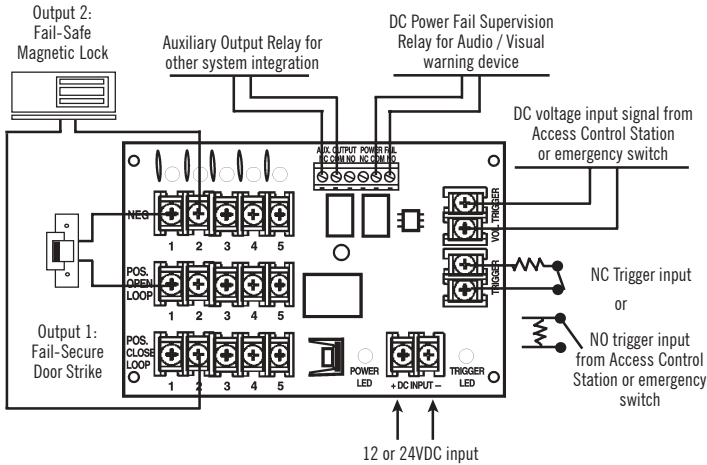

Table 1 – Terminal Function

Terminal Legend	Functions
TRIGGER	Used to connect N.O. or N.C. input trigger signal (supervised 2.2KΩ resistor) from access control panel. A short or open circuit will transfer power from "POS. CLOSE LOOP" to "POS. OPEN LOOP".
VOL. TRIGGER	Used to connect wet (5-30VDC) input trigger signal from access control panel. Applying Voltage will transfer power from "POS. CLOSE LOOP" to "POS. OPEN LOOP".
POWER FAIL	Used to notify loss of DC power. To connect a visual or audio warning device (such as siren or strobe light). Dry contact relay rated at 3 Amps @ 24VDC. If VDC input to the PDM is interrupted, the connected warning device will be activated.
AUX OUTPUT	Used to activate other auxiliary device when trigger signal is received from the "TRIGGER" or "VOL TRIGGER" terminals.
- DC INPUT +	12 or 24 VDC input from main board.

WARRANTY: This SECO-LARM product is warranted against defects in material and workmanship while used in normal service for a period of one (1) year from the date of sale to the original consumer customer. SECO-LARM's obligation is limited to the repair or replacement of any defective part if the unit is returned, transportation prepaid, to SECO-LARM. This Warranty is void if damage is caused by or attributed to acts of God, physical or electrical misuse or abuse, neglect, repair, or alteration, improper or abnormal usage, or faulty installation, or if for any other reason.

SECO-LARM determines that such equipment is not operating properly as a result of causes other than defects in material and workmanship. The sole obligation of SECO-LARM, and the purchaser's exclusive remedy, shall be limited to replacement or repair only, at SECO-LARM's option. In no event shall SECO-LARM be liable for any special, collateral, incidental, or consequential personal or property damages of any kind to the purchaser or anyone else.

NOTICE: The information and specifications printed in this manual are current at the time of publication. However, the SECO-LARM policy is one of continual development and improvement. For this reason, SECO-LARM reserves the right to change specifications without notice. SECO-LARM is also not responsible for misprints or typographical errors.

Copyright © 2011 SECO-LARM U.S.A., Inc. All rights reserved. This material may not be reproduced or copied, in whole or in part, without the written permission of SECO-LARM.