

Mini Vandal Dome Camera

EV-2125-N2WQ 420 TV lines, 2.9mm lens

Features:

- ▶ Heavy-duty, vandal-resistant design
- ▶ 1/3" Sony Super HAD II CCD
- ▶ 2.9mm Lens
- ▶ 420 TV Lines
- ▶ Small 3" (76mm) diameter
- ▶ Weatherproof (IP65)
- ▶ Low current draw

**Small
3-inch (76mm)
Diameter**

**IP65
Weatherproof**



Specifications:

Model	EV-2125-N2WQ
Type	Ultra-Mini Vandal Dome Camera
CCD	1/3" Sony Super HAD II
Resolution	420 TV lines
Lens size	2.9mm
Pickup elements (HxV)	510x492 pixels
Sync	Internal
Video output	1Vp-p composite video, 75Ω
Video output format	NTSC
S/N ratio	>48dB (AGS OFF)
Shutter control	Auto Electric Shutter (AES)
Gamma correction	0.45
Gain control	Auto
Minimum illumination	0.1 Lux/F1.2
Operating voltage	12VDC ±10%
Current draw	60mA
Operating temperature	-4°~122° F (-20°~50° C)
Dimensions	3"x2 ³ / ₈ " (76x60 mm)
Weight	6.4-oz (182g)

Note: PAL models also available as a special-order item. Contact SECO-LARM for details.

Rubber Seal:

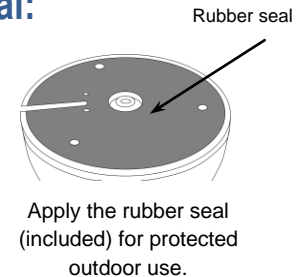

Dimensions:

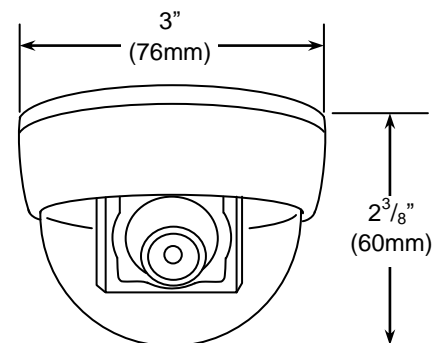

SECO-LARM

16842 Millikan Avenue
Irvine, CA 92606

Tel: 1-949-261-2999
1-800-662-0800
Fax: 1-949-261-7326

Web: www.seco-larm.com
Email: info@seco-larm.com



Copyright © 2011
SECO-LARM U.S.A., Inc.
All rights reserved