

Covert Ceiling Mount Camera

EV-6120-N3WQ - 480 TV Lines

EV-6620-N3WQ - 600 TV Lines

Features:

- 1/3" Sony Super HAD II CCD
- 3.7mm Lens
- Concealed cables
- 12VDC Operation
- Low current draw: 100mA.

Specifications:

Model #	EV-6120-N3WQ	EV-6620-N3WQ
Type	Covert Ceiling-Mount Camera	
CCD	1/3" Sony Super HAD II CCD	
Resolution	480 TVL	600 TVL
Pickup elements	510x492 pixels	768x494 pixels
Sync	Internal	
Video output	1.1Vp-p composite video, 75Ω	
S/N ratio	>48dB (AGC OFF)	
Shutter control	1/60~1/100,000 sec.	
Gain control	Auto	
Operating voltage	12VDC	
Current draw	100mA	
Operating temperature	14°~122° F (-10°~50° C)	
Dimensions	4 ³ / ₄ " x 2 ¹ / ₄ " (120 x 57 mm)	
Weight	5-oz (135g)	



Dimensions:

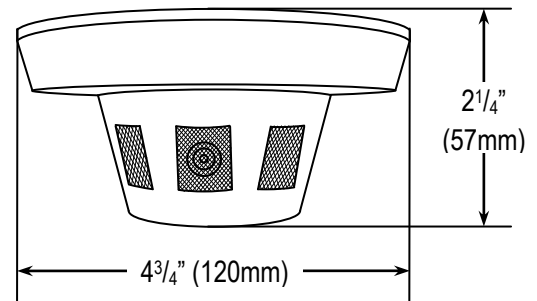

Related Products:



Surveillance-Mirror
Camera



Discreet Wall-Plate
Camera



PIR
Camera



Flush-Mount Ball
"UFO" Camera

SECO-LARM

16842 Millikan Ave • Irvine, CA 92606

Tel: 949-261-2999 / 800-662-0800 • Fax: 949-261-7328

sales@seco-larm.com • www.seco-larm.com



Copyright 2012 © SECO-LARM U.S.A., Inc. All rights reserved.
The SECO-LARM policy is one of continual development. For that reason, SECO-LARM reserves the right to change prices and specifications without notice. SECO-LARM is not responsible for misprints.

SECO-LARM CRIMEBUSTER® CBA SLI

pi-EV-6x20-N3WQ.docx