

Elite 3X 1000 TV Line Bullet Camera

EV-C1303-NMGQ

Features:

- 1000 TV Lines
- Megapixel CMOS
- Built-in service monitor port
- Weatherproof (IP67) for outdoor use
- DC Auto iris varifocal 2.8~12mm lens with ICR (IR Cut Filter)
- WDR (Wide Dynamic Range) provides clear images under intense backlight conditions
- Intelligent features such as motion detection and zoom control
- 32x DSS (Digital Slow Shutter) amplifies existing light to capture images in almost total darkness
- 3-Axis mounting arm
- 12VDC/24VAC Operation
- OSD (On-Screen Display) for convenient programming of special features
- Defog to improve image clarity in poor conditions



Specifications:

Type	Bullet	
CMOS	1/3" 1.3MP Sony IMX138	
Resolution	1000 TV Lines	
Effective pixels	1305x1049 pixels	
3D-NR	Yes	
WDR	Yes	
OSD Control	Yes	
Sync	Internal	
Video output format	1.0Vp-p Composite video, 75Ω	
Lens	2.8~12mm	
# of IR LEDs	42	
IR Range	Up to 100' (30m)	
Minimum illumination	0 Lux (IR LEDs on)	
Gamma correction	Yes	
S/N Ratio	>50dB	
Shutter control	Auto Electric Shutter (AES), 1/60~1/60,000 s	
Gain control	Auto	
White balance	Auto	
Operating voltage	12VDC/24VAC	
Current draw	LEDs OFF	190mA@12VDC
	LEDs ON	530mA@12VDC
IP Rating	IP67	
Operating temperature	-14°~122° F (-10~50° C)	
Dimensions	3 ¹⁵ / ₁₆ "x3 ¹⁵ / ₁₆ "x8 ¹ / ₄ " (100x100x210 mm)	
Weight	3-lb 1.4-oz (1,400g)	

3-Axis Mounting Bracket:

The camera angle adjustment screw, mounting arm adjustment screw, and adjustment nut can be loosened to adjust the camera's position.

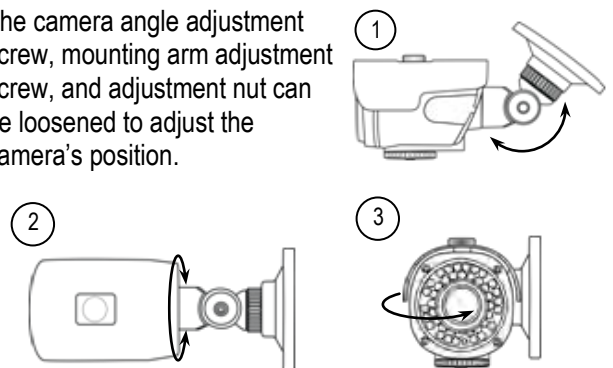

Easy Camera Adjustment:

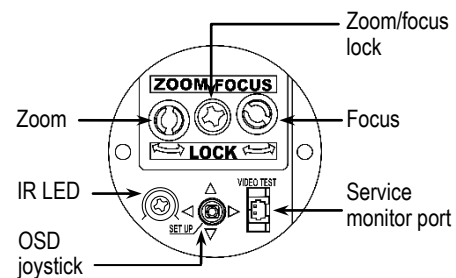

SECO-LARM® U.S.A., Inc.

16842 Millikan Avenue, Irvine, CA, 92606

Tel (CA & Int'l): (949) 261-2999 | (800) 662-0800

Website: www.seco-larm.com | Email: sales@seco-larm.com

FC CE RoHS ISO 9001

Copyright 2015 © SECO-LARM U.S.A., Inc. All rights reserved. The SECO-LARM policy is one of continual development. For that reason, SECO-LARM reserves the right to change prices and specifications without notice. SECO-LARM is not responsible for misprints.

SECO-LARM® ENFORCER® CRIMEBUSTER® CBA SLI®

PIEV-C1303-NMGQ_150217.docx.docx