

ENFORCER®

4-in-1 HD TVI, CVI, AHD, and Analog Specialty Cameras On-Screen Display Manual



For the following models:

Model #	Lens	Resolution	Voltage	Style
EV-Y4201-A2SQ	3.0mm	1080p	12VDC	Corner-Mount
EV-Y5105-N2SQ	2.9mm	1080p	12VDC	Wall-plate

Table of Contents:

Programmable Features.....	2	Day & Night.....	12~13
How to use the OSD Controller.....	3	Noise Reduction.....	13
Navigating the OSD.....	3	Special.....	14~17
Menu Diagram.....	4~6	Adjust.....	18
Lens.....	7	Exit.....	19
Exposure.....	7~9	Troubleshooting.....	20
Backlight.....	9~10	Warranty.....	20
White Balance.....	11		

Programmable Features:

• Multiple Output Formats

Select between multiple different formats: AHD, CVI, TVI, and CVBS

• Exposure

Adjust the shutter speed, automatic gain control (AGC), and defog settings

• Digital Wide Dynamic Range (D-WDR)

Provide clear images even under circumstances where backlight illumination can vary

• Back Light Compensation (BLC)

Adjust the exposure to properly display the subject in front of bright light sources

• Highlight Suppression Back Light Compensation (HSBLC)

Define target areas and remove spotlights to make certain objects visible

• White Balance

Adjust the picture's color temperature/image color

• Day & Night

Adjust the level of ambient light that triggers the camera to switch between color and B/W modes

• Noise Reduction (DNR)

Adjust for less interference on the screen in an area with low illumination

• Privacy

Block out or distort a portion of the image

• Motion Detection

Detect and highlight motion in the scene



D-WDR OFF



D-WDR ON



BLC OFF



BLC ON



HSBLC OFF



HSBLC ON

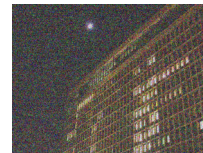

DNR OFF

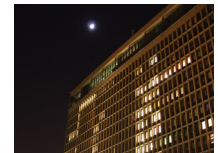

DNR ON



Privacy OFF

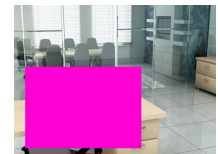

Privacy ON

Note: All screen images in this manual are simulated.

How to use the OSD Controller:

1. Press down on the joystick to open the on-screen display (OSD) menu.
2. Use the joystick to navigate the OSD menu.
3. To select an item, press down (enter) on the joystick.
4. To change the output format:
 - a. Using the OSD controller, press the controller in the direction of the desired setting, hold for 5 seconds, and release when the camera restarts. See chart below.

EV-Y4201-A2SQ

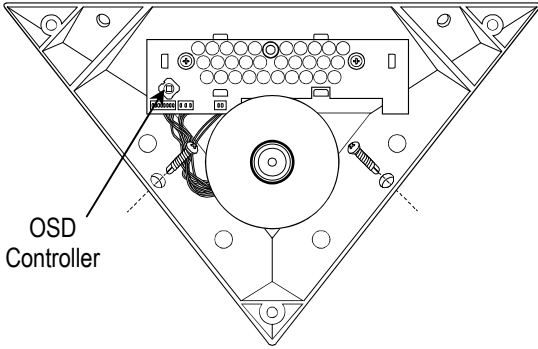

EV-Y5105-N1SQ



EV-Y4201-A2SQ

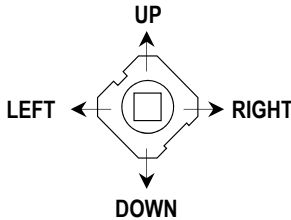

Direction	Format Setting
Up	CVI
Down	TVI
Left	CVBS
Right	AHD

Navigating the OSD:

1. Press down (enter) on the joystick.
The Main Menu will be displayed on the monitor.
2. Move to and highlight the required function by moving the joystick up and down.
3. Select the required function by pressing enter on the joystick.
4. Change the menu setting by moving the joystick left or right.
5. After choosing the settings, move the cursor to EXIT and select the option to SAVE & END, RESET, or NOT SAVE.
6. Press enter on the joystick to make the selection and leave the OSD menu.

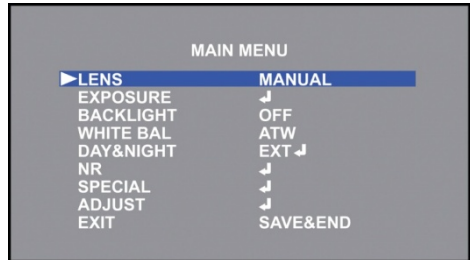

NOTE: A submenu is available where the menu displays ↵.

ENFORCER 4-in-1 HD TVI, CVI, AHD, Analog Corner-Mount Camera

Menu Diagram:

MAIN MENU		SETTING	SETTING OPTIONS	
LENS (PAGE 7)	MANUAL	SET FOR FIXED LENS CAMERAS		
	DC	MODE	INDOOR	
			OUTDOOR	
		IRIS SPEED: 1~15		MIN SHUTTER: 1/30 MAX SHUTTER: 1/60, FLK, 1/240, 1/480, 1/1000, 1/2000, 1/5000, 1/10000, 1/50000
EXPOSURE (PAGE 7-8)	SHUTTER	AUTO, 1/30, 1/60, FLK, 1/240, 1/480, 1/1000, 1/2000, 1/5000, 1/10000, 1/50000, X2, X4, X6, X8, X10, X15, X20, X25, X30		
	AGC: 0~15			
	SENS-UP	OFF		
		AUTO	SENS-UP: X2, X4, X6, X8, X10, X15, X20, X25, X30	
	BRIGHTNESS: 1~100			
	D-WDR	OFF		
		ON	LEVEL: 0~8	
		AUTO		
	DEFOG	OFF		
		AUTO	POS/SIZE: ADJUST POSITION AND SIZE OF BOX	
GRADATION: 0~2				
DEFAULT: RESET TO DEFAULT SETTINGS				
BACKLIGHT (PAGE 9-10)	OFF			
	BLC	LEVEL: LOW / MIDDLE / HIGH		
		AREA: ADJUST POSITION AND SIZE OF BOX		
		DEFAULT: RESET TO DEFAULT SETTINGS		
	HSBLC	SELECT: AREA 1 / AREA 2 / AREA 3 / AREA 4		
		DISPLAY	ON: ADJUST POSITION AND SIZE OF BOX	
			OFF	
		BLACK MASK: ON / OFF		
		LEVEL: 0~100		
		MODE	ALL DAY	
NIGHT			AGC LEVEL: 0~255	
DEFAULT: RESET TO DEFAULT SETTINGS				
WHITE BAL (PAGE 11)	ATW			
	AWC-> SET: PRESS ENTER TO SET			
	INDOOR			
	OUTDOOR			
	MANUAL	BLUE: 0~100		
		RED: 0~100		
	AWB			

Menu Diagram (continued):

MAIN MENU		SETTING	SETTING OPTION		
DAY & NIGHT (PAGE 12~13)	EXT	D->N (DELAY): 0~60			
		N->D (DELAY): 0~60			
	AUTO	D->N (CDS): 6~255			
		D->N (DELAY): 0~60			
		N->D (CDS): 1~249			
		N->D (DELAY): 0~60			
	COLOR				
	B/W	BURST: OFF / ON			
		IR SMART	OFF		
			ON	LEVEL: 0~15	
			AREA: ADJUST POSITION AND SIZE OF BOX		
NR (PAGE 13)	2DNR: OFF / LOW / MIDDLE / HIGH				
	3DNR: OFF / LOW / MIDDLE / HIGH				
SPECIAL (PAGE 14~16)	CAM TITLE	OFF			
		ON: A/B/C... 1/2/3...			
	D-EFFECT	FREEZE: OFF / ON			
		MIRROR: OFF / MIRROR / V-FLIP / ROTATE			
		NEG. IMAGE: OFF / ON			
	MOTION	OFF			
		ON	SELECT: AREA 1 / AREA 2 / AREA 3 / AREA 4		
			DISPLAY	ON: ADJUST POSITION AND SIZE OF BOX	
				OFF	
			SENSITIVITY: 0~100		
			COLOR: GREEN / BLUE / WHITE / RED		
		TRANS: 0.00 / 0.25 / 0.75 / 1.00			
		ALARM	VIEW TYPE: ALL / OFF / BLOCK / OUTLINE		
			OSD VIEW: ON / OFF		
			ALARM OUT.: ON / OFF		
				TIME: 0~15	
				DEFAULT: RESET TO DEFAULT SETTINGS	
	PRIVACY	OFF			
		ON	SELECT: AREA 1 / AREA 2 / AREA 3 / AREA 4		
			DISPLAY	OFF	
MOSIAC: ADJUST POSITION AND SIZE OF BOX					
INV.: ADJUST POSITION AND SIZE OF BOX					
COLOR: ADJUST POSITION AND SIZE OF BOX					
COLOR: WHITE / BLACK / RED / BLUE / YELLOW / GREEN / CYAN / USER					
TRANS: 0.25 / 0.50 / 0.75 / 1.00					
DEFAULT: RESET TO DEFAULT SETTINGS					

ENFORCER 4-in-1 HD TVI, CVI, AHD, Analog Corner-Mount Camera

Menu Diagram (continued):

MAIN MENU		SETTING	SETTING OPTION	
SPECIAL (PAGE 16~17)	LANGUAGE: ENG / CHN1 / CHN2 / GER / FRA / ITA / SPA / POL / RUS / POR / NED / TUR / KOR / JPN / HEB / ARB			
	DEFECT	LIVE DPC	OFF	
			ON	AGC LEVEL: 0~255
				LEVEL: 0~100
		WHITE DPC	ON	OFF
				POS/SIZE: ADJUST POSITION AND SIZE OF BOX
				START: CLOSE THE IRIS THEN PRESS ENTER
				DPC VIEW: OFF / ON
				LEVEL: 0~100
				AGC: 0~14
		SENS-UP: X2, X4, X6, X8, X10, X15, X20, X25, X30		
		BLACK DPC	ON	OFF
				POS/SIZE: ADJUST POSITION AND SIZE OF BOX
	START: PRESS ENTER			
	DPC VIEW: OFF / ON			
LEVEL: 0~100				
RS485	CAMID: 0~255			
	ID DISPLAY: OFF / ON			
	BAUD RATE: 2400 / 4800 / 9600 / 19200 / 38400			
ADJUST (PAGE 18)	SHARPNESS	AUTO	LEVEL: 0~10	
			START AGC: 0~255	
			END AGC: 0~255	
		OFF		
	MONITOR	LCD	BLACK LEVEL: 0~60	
			GAMMA: USER / 0.45 / 0.50 / 0.55 / 0.60 / 0.65 / 0.70 / 0.75 / 0.80 / 0.85 / 0.90 / 0.95 / 1.00	
			BLUE GAIN: 0~100	
		RED GAIN: 0~100		
		CRT	BLACK LEVEL: 0~60	
			BLUE GAIN: 0~100	
	RED GAIN: 0~100			
	LSC: OFF / ON			
	VIDEO OUT: NTSC / PAL			
	COMET: OFF / ON			
	EXIT (PAGE 19)	SAVE & END		
RESET				
NOT SAVE				

Lens:

This function is used to select the camera's lens operation.

1. Select LENS on the Main Menu screen.
2. Select the desired Lens operation by moving the joystick to the left or right and pressing enter to enter the sub-menu (if applicable).
3. Use the joystick to adjust the settings.
4. Select RETURN to return to the Main Menu screen.

- **MANUAL:** Select MANUAL mode for manual or fixed lens.

- **DC:** Select DC mode for DC Auto Iris lens.

- o **MODE:** Select INDOOR or OUTDOOR mode

- **INDOOR:** Use for indoor installations.
- **OUTDOOR:** Use for outdoor installations. Enter menu to adjust settings.

- **MIN SHUT:** The minimum shutter speed is preset to 1/30.

- **MAX SHUT:** Set the maximum shutter speed to FLK, 1/60~1/50000 (Default: 1/2000).

- o **IRIS SPEED:** Set the reaction speed of the iris from 0~15 (Default: 8).
- o **RETURN:** Return to the Main Menu screen.

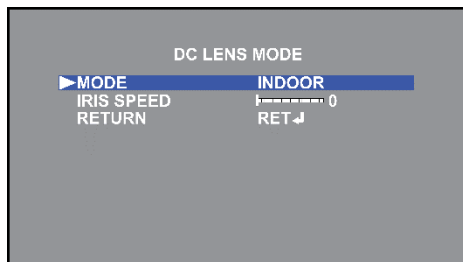

Exposure:

This function is used to select the camera's exposure settings, including shutter speed, AGC, SENS-UP, brightness, WDR, and defog settings.

1. Select EXPOSURE on the Main Menu screen.
2. Press enter to enter the Exposure menu screen.
3. Select the desired Exposure operation by moving the joystick up or down, and select the desired setting by moving the joystick left or right and pressing enter to enter the sub-menu (if applicable).
4. Select RETURN to return to the Main Menu screen.

- **SHUTTER:** Set the shutter speed to AUTO, 1/30~1/50000, x2~x30 (Default: AUTO).

NOTE: If LENS is set to DC AUTO IRIS then SHUTTER is not available in this menu.

- **AGC:** Adjust the Auto Gain Control (AGC) for better picture brightness in low light conditions. Adjust from 1~15 (Default: 15).

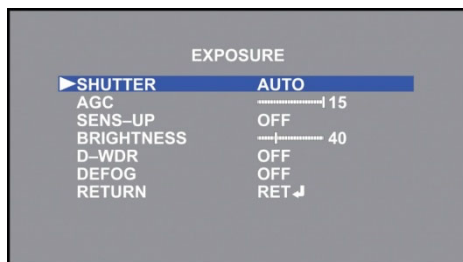

Exposure (continued):

- **SENS-UP:** Activates the digital slow shutter for use in darker images.
 - OFF: Turn SENS-UP off.
 - AUTO: Turn SENS-UP to automatic mode. Enter menu to adjust settings.
 - SENS-UP: Higher values increase the brightness of the image but also potentially increase after images. Adjust from x2~x30 (Default: x4).
 - RETURN: Return to the EXPOSURE menu screen.

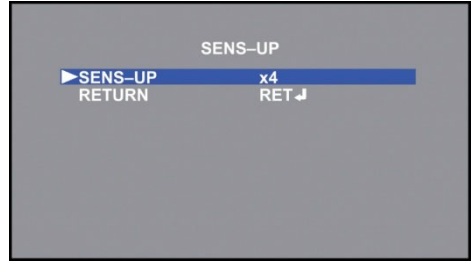

NOTE: This option is only available if SHUTTER is set to AUTO or 1/30 and if AGC is not set to 0.

- **BRIGHTNESS:** Adjust the camera's brightness from 0~100 (Default: 50).
- **D-WDR:** Adjust the camera's digital wide dynamic range (D-WDR) settings to provide clear images even under intense back light conditions.
 - OFF: Turn D-WDR off.
 - ON: Turn D-WDR on. Enter menu to adjust settings.
 - LEVEL: Higher values increase the D-WDR effect. Adjust from 0~8 (Default: 5).
 - RETURN: Return to the EXPOSURE menu screen.
 - AUTO: Turn D-WDR to automatic mode.

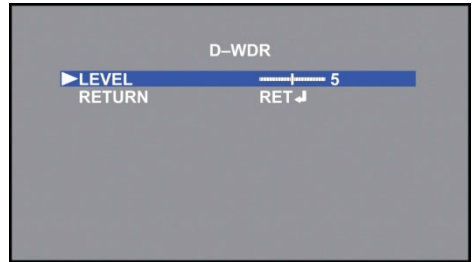

D-WDR OFF

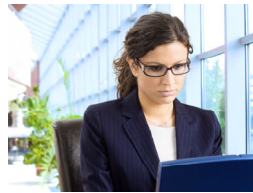

D-WDR HIGH

Exposure (continued):

- **DEFOG:** Adjust the camera's defog settings for clearer images in environments with fog or mist.
 - o OFF: Turn DEFOG off.
 - o AUTO: Turn DEFOG to automatic mode. Enter menu to adjust settings.
 - POS/SIZE: Adjust the position and size of the defog mask.
 - GRADATION: Higher values increase the effect of the defog mask. Adjust from 0~2 (Default: 0).
 - DEFAULT: Return the DEFOG settings to their default values.
 - RETURN: Return to the EXPOSURE menu screen.
- **RETURN:** Return to the Main Menu screen.

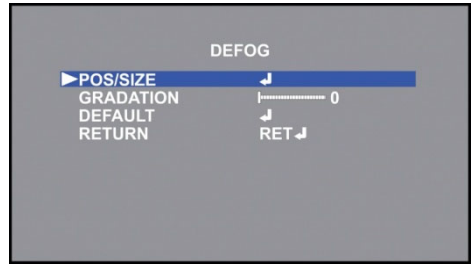

Backlight:

This function is used to control the light level to overcome strong backlight conditions.

1. Select BACKLIGHT on the Main Menu screen.
 2. Select the desired Backlight operation by moving the joystick to the left or right and pressing enter to enter the sub-menu (if applicable).
 3. Use the joystick to adjust the settings.
 4. Select RETURN to return to the Main Menu screen.
- **OFF:** Turn the BLC or HSBLC functions off.
 - **BLC:** Select Back Light Compensation (BLC) to correct the exposure of the subjects that are in front of a strong backlight. Enter menu to adjust settings.
 - o LEVEL: Set the BLC level between LOW, MIDDLE, or HIGH (Default: MIDDLE).
 - o AREA: Adjust the position and size of the BLC zone.
 - o DEFAULT: Return the BLC settings to their default values.
 - o RETURN: Return to the MAIN MENU screen.

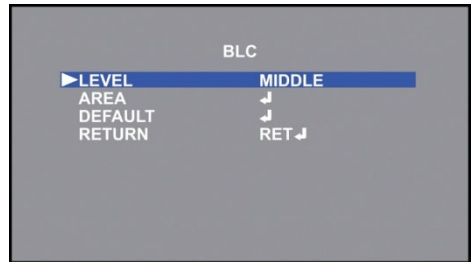

BLC OFF



BLC ON

Backlight (continued):

- **HSBLC:** Select Highlight Suppression Back Light Compensation (HSBLC) to improve the clarity of the picture by blocking a strong backlight. Enter menu to adjust settings.
 - **SELECT:** Select the HSBLC area to be modified. Up to 4 areas can be used.
 - **DISPLAY:** Turn the selected HSBLC area ON or OFF (Default: ON).
 - **BLACK MASK:** Select whether the HSBLC areas will display a black mask or not (Default: ON).
 - **LEVEL:** Adjust the sensitivity of the HSBLC area. Adjust from 0~100 (Default: 20).
 - **MODE:** Select whether the HSBLC will be appear ALL DAY or only during the NIGHT (Default: NIGHT).
 - **ALL DAY:** The HSBLC areas are active at all times.
 - **NIGHT:** The HSBLC areas are only active when a given AGC level is reached.
 - **AGC LEVEL:** Higher values will block out stronger light sources. Adjust from 0~255 (Default: 48).
 - **RETURN:** Return to the HSBLC menu.
 - **DEFAULT:** Return the HSBLC settings to their default values.
 - **RETURN:** Return to the MAIN MENU screen.

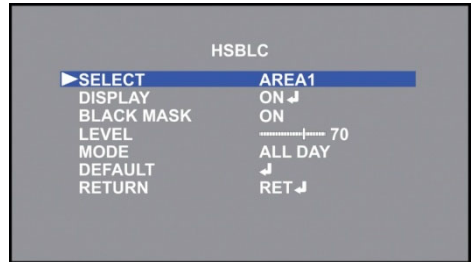

HSBLC OFF



HSBLC ON

White Balance:

This function is used to adjust the color temperature and image color of the picture.

1. Select **WHITE BAL** on the Main Menu screen.
 2. Select the desired White Balance operation by moving the joystick to the left or right and pressing enter to enter the sub-menu (if applicable).
 3. Use the joystick to adjust the settings.
 4. Select **RETURN** to return to the Main Menu screen.
-
- **ATW**: Select Automatic Tracking White Balance (ATW) to automatically adjust the white balance color temperature range from 2,500°~9,500°K when the image color temperature changes.
 - **AWC → SET**: Select Automatic White balance Control (AWC) → SET to manually adjust the white balance for the current area. Point the camera towards a blank white sheet of paper and press enter to set the white balance.
 - **INDOOR**: Select **INDOOR** for general indoor applications. Use this mode for color temperature ranges from 2,800°~5,600°K.
 - **OUTDOOR**: Select **OUTDOOR** for general outdoor applications. Use this mode for color temperature ranges from 3,200°~6,400°K.
 - **MANUAL**: Select **MANUAL** to manually adjust the blue and red color temperature values for the area.
 - **BLUE**: Set the blue gain value. Adjust from 0~100 (Default: 50).
 - **RED**: Set the red gain value. Adjust from 0~100 (Default: 50).
 - **RETURN**: Return to the **MAIN MENU** screen.
 - **AWB**: Select Auto White Balance (AWB) to automatically adjust the white balance color temperature range from 0°~10,500°K when the image color temperature changes.

Day & Night:

This function is used to adjust the transition between color and black & white modes automatically based on the current lighting conditions.

1. Select DAY & NIGHT on the Main Menu screen.
2. Select the desired Day & Night operation by moving the joystick to the left or right and pressing enter to enter the sub-menu (if applicable).
3. Use the joystick to adjust the settings.
4. Select RETURN to return to the Main Menu screen.

- **EXT:** Select External (EXT) mode to automatically switch between Color and B/W modes by using the integrated IR CDS sensor.

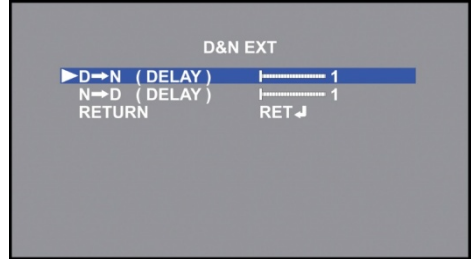

- o D→N (DELAY): Set the delay time for switching between day and night modes. Adjust from 0~60 (Default: 3).
- o N→D (DELAY): Set the delay time for switching between night and day modes. Adjust from 0~60 (Default: 3).
- o RETURN: Return to the MAIN MENU screen.

- **AUTO:** Select AUTO mode to automatically switch between Color and B/W modes by using AGC values set by the camera.

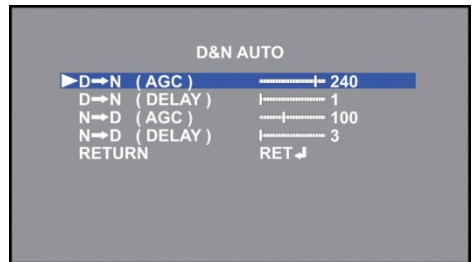

- o D→N (CDS): Set the CDS sensor threshold for the camera. When the threshold is reached the camera will switch between day and night modes. Adjust from 6~255 (Default: 200).
- o D→N (DELAY): Set the delay time for switching between day and night modes. Adjust from 0~60 (Default: 1).
- o N→D (CDS): Set the CDS sensor threshold for the camera. When the threshold is reached the camera will switch between night and day modes. Adjust from 1~249 (Default: 80).
- o N→D (DELAY): Set the delay time for switching between night and day modes. Adjust from 0~60 (Default: 5).
- o RETURN: Return to the MAIN MENU screen.

Day & Night (continued):

- **COLOR:** Select COLOR to force the camera to display in color mode at all times.
- **B/W:** Select B/W to force the camera to display in B/W mode at all times.
 - o BURST: Enable or disable the color burst when the camera switches from Color to B/W.
 - o IR SMART: The Smart IR feature adjusts the electronic shutter to adjust the IR exposure.
 - OFF: Turn the Smart IR function off.
 - ON: Turn the Smart IR function on.
 - LEVEL: Adjust the level of the Smart IR. Adjust from 0~15 (Default: 3).
 - AREA: Adjust the position and size of the Smart IR area.
 - RETURN: Return to the B/W menu screen.
 - o RETURN: Return to the EXPOSURE menu screen.

NOTE: If DAY & NIGHT is set to B/W then WHITE BAL is not available.

Noise Reduction:

This function is used to reduce the noise on the screen and allows for clearer images in low light conditions.

1. Select NR on the Main Menu screen.
2. Press enter to enter the Noise Reduction menu screen.
3. Select the desired Noise Reduction operation by moving the joystick up or down, and select the desired setting by moving the joystick left or right.
4. Select RETURN to return to the Main Menu screen.

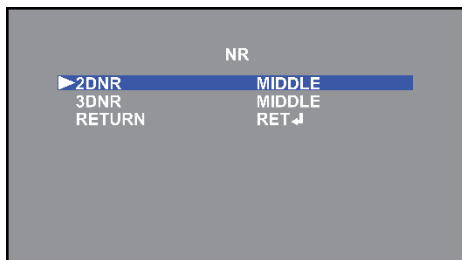

- **2DNR:** Select the 2D Digital Noise Reduction (2DNR) for general lighting conditions. Higher levels of DNR will decrease the noise in the image but also potentially affect the sharpness. Adjust from OFF~HIGH (Default: MIDDLE).
- **3DNR:** Select the 3D Digital Noise Reduction (3DNR) for low lighting conditions. Higher levels of DNR will decrease the noise in the image but also potentially increase after images. Adjust from OFF~HIGH (Default: MIDDLE).
- **RETURN:** Return to the MAIN MENU screen.

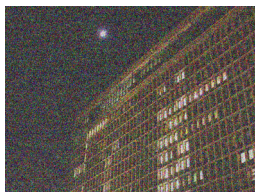

DNR OFF



DNR ON

Special:

This function accesses the special features of the camera including the camera title, digital effects, motion detection, privacy masks, OSD language, and defective pixel correction (DPC).

1. Select SPECIAL on the Main Menu screen.
2. Select the desired menu operation by moving the joystick to the left or right and pressing enter to enter the sub-menu (if applicable).
3. Use the joystick to adjust the settings.
4. Select RETURN to return to the Main Menu screen.

- **CAM TITLE:** Set the camera title to on or off.

The default camera title is the firmware version.

- o OFF: Camera title off.
- o ON: Camera title on. Use the joystick to select the camera title. Up to 15 alphanumeric characters can be used.

- **D-EFFECT:** Select to choose a digital effect to apply to the camera.

- o FREEZE: Freeze the camera image at the selected moment.
- o MIRROR: Flip the camera image horizontally, vertically, or horizontally and vertically.
- o NEG IMAGE: Invert the camera image colors.
- o RETURN: Return to the SPECIAL menu screen.



Special (continued):

- **MOTION:** This function is used to detect moving objects on-screen.

○ OFF: Turn motion detection off.

○ ON: Turn motion detection on.

▪ **SELECT:** Select which of the four motion detection zones to modify.

▪ **DISPLAY:** Turn the selected motion detection zone on or off.

● OFF: The selected motion detection zone is turned off.

● ON: Adjust the position and size of the selected motion detection zone.

▪ **SENSITIVITY:** Adjust the sensitivity of the selected motion detection zone. Adjust from 0~100 (Default: 64).

▪ **COLOR:** Select the color of the selected motion detection zone. Select from Green, Blue, White, and Red.

▪ **TRANS:** Set the selected motion detection zone's transparency. Adjust from 0.00~1.00 (Default: 1.00).

▪ **ALARM:** Adjust settings for the motion detection notifications.

● **VIEW TYPE:** Select between different view modes for motion detection.

○ OFF: Does not show any of the motion detection zones when motion is detected.

○ BLOCK: Shows small blocks over the motion in the detection zone that is triggered.

○ OUTLINE: Shows an outline around the motion in the detection zone that is triggered.

○ ALL: Shows blocks and an outline of all motion detection zones when motion is detected.

● **OSD VIEW:** When turned on, MOTION DETECTED will display when any of the motion detection zones are triggered.

● **ALARM OUT:** Not used.

● **TIME:** Set the amount of time that the motion detection alerts remain on the screen. Adjust from 0~15 seconds (Default: 3).

● **RETURN:** Return to the MOTION menu screen.

▪ **DEFAULT:** Return the MOTION settings to their default values.

▪ **RETURN:** Return to the MAIN MENU screen.

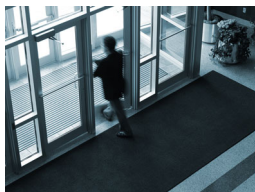
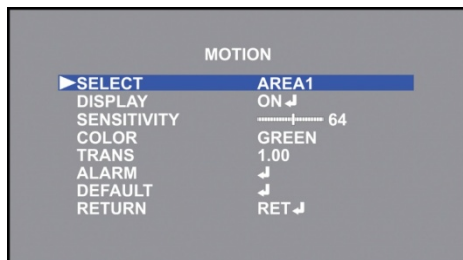

Motion Detection OFF

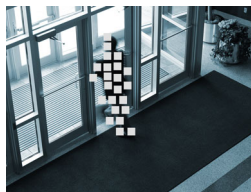

Motion Detection ON

Special (continued):

- **PRIVACY:** This function is used to distort or block out certain portions of the image for privacy reasons.

- OFF: Turn the privacy feature off.
- ON: Turn the privacy feature on.
 - **SELECT:** Select which of the four privacy screens to modify.
 - **DISPLAY:** Select how to display the selected privacy screen.
 - OFF: Turn the selected privacy screen off.
 - MOSAIC: Shows the privacy screen as distorted blocks.
 - INV: Shows the privacy screen as a negative image.
 - COLOR: Shows the privacy screen as a solid color.
 - **COLOR:** Select the color of the selected privacy screen. Select from White, Black, Red, Blue, Yellow, Green, Cyan, or User (Dark Green).
 - **TRANS:** Set the selected privacy screen's transparency. Adjust from 0.00~1.00 (Default: 1.00).
 - **DEFAULT:** Return the PRIVACY settings to their default values.
 - **RETURN:** Return to the MAIN MENU screen.

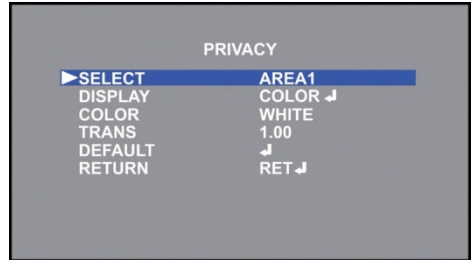

Privacy OFF



**Privacy ON
with Color Screen**



**Privacy ON
with Mosaic Screen**

- **LANGUAGE:** Set the desired OSD menu language. Select from English, Chinese1 (Simplified), Chinese2 (Traditional), German, French, Italian, Spanish, Polish, Russian, Portuguese, Dutch, Turkish, Korean, Japanese, Hebrew, or Arabic.

Special (continued):

- **DEFECT:** The camera can compensate for false white or black pixels.
 - **LIVE DPC:** The camera will automatically compensate for false white or black pixels.
 - **OFF:** Turn Live DPC off.
 - **ON:** Turn Live DPC on.
 - **AGC LEVEL:** Adjust from 0~255 (Default: 16).
 - **LEVEL:** Adjust from 0~100 (Default: 16).
 - **RETURN:** Return to the DEFECT menu.
 - **WHITE DPC:** The camera will compensate for false white pixels.
 - **OFF:** Turn White DPC off.
 - **ON:** Turn White DPC on.
 - **POS/SIZE:** Adjust the position and size of the White DPC area.
 - **START:** Close the iris then press enter to start.
 - **DPC VIEW:** Turn on to view any existing defective pixels.
 - **LEVEL:** Adjust from 0~100 (Default: 15).
 - **AGC:** Adjust from 0~14 (Default: 14).
 - **SENS-UP:** Adjust from x2~x30 (Default: x8).
 - **RETURN:** Return to the DEFECT menu.
 - **BLACK DPC:** The camera will compensate for false black pixels.
 - **OFF:** Turn Black DPC off.
 - **ON:** Turn Black DPC on.
 - **POS/SIZE:** Adjust the position and size of the Black DPC area.
 - **START:** Press enter to start.
 - **DPC VIEW:** Turn on to view any existing defective pixels.
 - **LEVEL:** Adjust from 0~100 (Default: 100).
 - **RETURN:** Return to the DEFECT menu.
 - **RETURN:** Return to the SPECIAL menu screen.
- **RS485:** Not used.
- **RETURN:** Return to the MAIN MENU screen.

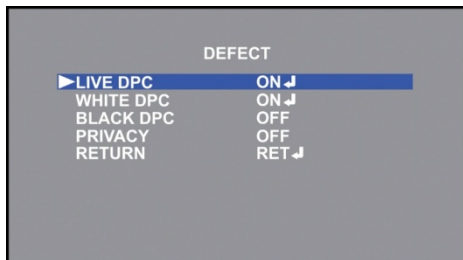

Adjust:

This function access video output functions such as sharpness, monitor type, and video output.

1. Select ADJUST on the Main Menu screen.
2. Select the desired menu operation by moving the joystick to the left or right and pressing enter to enter the sub-menu (if applicable).
3. Use the joystick to adjust the settings.
4. Select RETURN to return to the Main Menu screen.

- **SHARPNESS:** Adjust the sharpness of the image.

- OFF: No sharpness adjustment.
- AUTO: Adjust the level at which the sharpness adjustments will take place.
 - LEVEL: Higher values will result in a sharper image. Adjust from 0~10 (Default: 9).
 - START AGC: Select the AGC value where the sharpness adjustments will start. Adjust from 0~255 (Default: 120).
 - END AGC: Select the AGC value where the sharpness adjustment will end. Adjust from 0~255 (Default: 255).
 - RETURN: Return to the ADJUST menu screen.

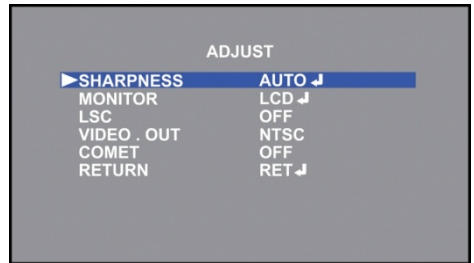

- **MONITOR:** Adjust the camera's image according to the type of monitor being used.

- LCD: Select for LCD monitors.
 - BLACK LEVEL: Adjust the black level of the image. Adjust from 0~60 (Default: 5).
 - GAMMA: Adjust the gamma level of the image. Adjust from USER, 0.45~1.00 (Default: 0.50).
 - BLUE GAIN: Adjust the blue gain of the image. Adjust from 0~100 (Default: 48).
 - RED GAIN: Adjust the red gain of the image. Adjust from 0~100 (Default: 48).
 - RETURN: Return to the ADJUST menu screen.
- CRT: Select for CRT monitors.
 - BLACK LEVEL: Adjust the black level of the image. Adjust from 0~60 (Default: 10).
 - BLUE GAIN: Adjust the blue gain of the image. Adjust from 0~100 (Default: 50).
 - RED GAIN: Adjust the red gain of the image. Adjust from 0~100 (Default: 50).
 - RETURN: Return to the ADJUST menu screen.

- **LSC:** Lens Shading Correction (LSC) adjust the shading of the outside of the image.

- **VIDEO OUT:** Select between NTSC and PAL outputs.

- **COMET:** Switches the camera image to black & white mode.

- **RETURN:** Return to the Main Menu screen.

Exit:

This function is used to save all OSD changes and exit the menu screen, reset all values to their factory defaults, or exit the menu screen without saving any changes.

1. Select EXIT on the Main Menu screen.
 2. Select the desired operation by moving the joystick to the left or right and pressing enter.
- **SAVE & END:** Save all OSD changes and exit the OSD menu.
 - **RESET:** Restore all OSD settings to factory defaults and exit the OSD menu.
 - **NOT SAVE:** Exit the OSD menu without saving any changes.

ENFORCER 4-in-1 HD TVI, CVI, AHD, Analog Corner-Mount Camera

Troubleshooting:

The screen is black	<ul style="list-style-type: none">• Check that the camera is powered up• Check that the power supply's polarity is correct• Check that the monitor is powered up• Check that the video cable connecting the camera to the monitor is connected properly
The image is foggy or washed out at night	<ul style="list-style-type: none">• Check that there are no objects very close to the camera• Check that there are no highly reflective objects in the scene
The screen image is dim	<ul style="list-style-type: none">• Clean the lens using a soft, clean cloth• Check that the light source is adequate
The screen image has poor contrast	<ul style="list-style-type: none">• Adjust the monitor's contrast knob• Change the position of the camera
The screen image flickers	<ul style="list-style-type: none">• Change the position of the camera, check cables and format setting
The screen image is distorted	<ul style="list-style-type: none">• Change the position of the camera, check cables and format setting
The camera case is hot	<ul style="list-style-type: none">• Check that the correct power supply is in use
IR LEDs do not turn on	<ul style="list-style-type: none">• Check that the correct power supply is in use

IMPORTANT: Users and installers of this product are responsible for ensuring this product complies with all national, state, and local laws and statutes related to monitoring and recording audio and video signals. SECO-LARM will not be held responsible for the use of this product in violation of any current laws or statutes.

FCC COMPLIANCE STATEMENT

Information to the user: This equipment has been tested and found to comply with the limits for a class B digital device, pursuant to part 15 of the FCC rules. These limits are designed to provide reasonable protection against harmful interference when the equipment is operated in a commercial environment. This equipment generates, uses, and can radiate radio frequency energy and, if not installed and used in accordance with the instruction manual, may cause harmful interference to radio communications. Operation of this equipment in a residential area is likely to cause harmful interference in which case the user will be required to correct the interference at his or her own expense.

WARRANTY: This SECO-LARM product is warranted against defects in material and workmanship while used in normal service for three (3) years from the date of sale to the original customer. SECO-LARM's obligation is limited to the repair or replacement of any defective part if the unit is returned, transportation prepaid, to SECO-LARM. This Warranty is void if damage is caused by or attributed to acts of God, physical or electrical misuse or abuse, neglect, repair or alteration, improper or abnormal usage, or faulty installation, or if for any other reason SECO-LARM determines that such equipment is not operating properly as a result of causes other than defects in material and workmanship. The sole obligation of SECO-LARM and the purchaser's exclusive remedy, shall be limited to the replacement or repair only, at SECO-LARM's option. In no event shall SECO-LARM be liable for any special, collateral, incidental, or consequential personal or property damage of any kind to the purchaser or anyone else.

NOTICE: The SECO-LARM policy is one of continual development and improvement. For that reason, SECO-LARM reserves the right to change specifications without notice. SECO-LARM is also not responsible for misprints.

Copyright © 2016 SECO-LARM U.S.A., Inc. All rights reserved. This material may not be reproduced or copied, in whole or in part, without the written permission of SECO-LARM.

SECO-LARM® U.S.A., Inc.

16842 Millikan Avenue, Irvine, CA 92606
Phone: (949) 261-2999 | (800) 662-0800

Website: www.seco-larm.com
Email: sales@seco-larm.com

 PIKSR1

Mi-EV-Y4201-XXSQ_OSD_181017.docx