

# **ENFORCER®**

## **Wireless Video Door Phone**

DP-266-1C7Q

### **Installation Manual**



The ENFORCER Wireless Video Door Phone is a convenient and secure way to monitor and control an entryway, such as a door or gate, from up to 492 feet (150 meters)\* away. When a guest or visitor presses the doorbell button on the camera unit, the homeowner can use one of up to three lightweight, wireless LCD monitors† to see who is requesting entry, speak with the caller, take a photo, and decide whether to grant entry. The video door phone can be expanded with up to two additional monitors and one additional camera. If multiple monitors are set up, then the system can also be used as an intercom system between each monitor.

- Wireless operation – camera and monitor can operate from up to 492ft (150m)\* away
- Remotely and securely talk to visitors and unlock doors or gates via the monitor
- Monitor can be carried around the premises while talking to the visitor
- Connect up to two additional monitors and one additional camera†
- Intercom calling between paired monitors†
- Camera has built-in IR LEDs for nighttime use
- Camera powered by 9~16 VAC/5~16 VDC
- Camera includes a built-in PIR sensor that activates the camera and takes photos of the visitor when they approach
- Monitor includes a kickstand
- Monitor front door at any time
- Egress input
- 170° wide field of view
- Adjustable camera pan and tilt angle—up to 20° from centerline in any direction—to allow for mounting variations

\*Line-of-sight range. Actual range may vary depending on the installation and operating environment.

†Additional monitors and camera sold separately.

**Parts List****DP-266-1C7Q** *Complete Kit*

1x <b>Monitor (DP-266-M7Q)*</b>	1x <b>Camera (DP-266-CAQ)*</b>
1x <b>Monitor battery</b>	1x <b>Manual</b>
1x <b>Camera battery</b>	1x <b>Camera screw cover</b>
1x <b>Camera screw</b>	
1x <b>DC Jack with pigtail</b>	
1x <b>Camera mounting hood bracket</b>	
1x <b>AC Power adapter with DC plug (for monitor)</b>	
1x <b>AC Power adapter with DC plug (for camera)</b>	
3x <b>Camera mounting screws</b>	
3x <b>Camera mounting screw anchors</b>	
1x <b>Monitor wall-mount bracket</b>	
4x <b>Monitor wall-mount bracket screws</b>	
4x <b>Monitor wall-mount screw anchors</b>	

**DP-266-CAQ** *Additional Camera Unit†*

1x <b>Camera (DP-266-CAQ)</b>	1x <b>Camera screw</b>
1x <b>Camera battery</b>	1x <b>DC Jack with pigtail</b>
1x <b>Manual</b>	1x <b>Camera screw cover</b>
3x <b>Camera mounting screw anchors</b>	
3x <b>Camera mounting screws</b>	
1x <b>AC Power adapter with DC plug (for camera)</b>	
1x <b>Camera mounting hood bracket</b>	

**DP-266-M7Q** *Additional Monitor Unit†*

1x <b>Monitor (DP-266-M7Q)</b>	1x <b>Manual</b>
1x <b>Monitor battery</b>	
1x <b>AC Power adapter with DC plug (for monitor)</b>	
1x <b>Monitor wall-mount bracket</b>	
4x <b>Monitor wall-mount bracket screws</b>	
4x <b>Monitor wall-mount screw anchors</b>	

\*The DP-266-1C7Q included monitor and camera are paired by default.

†Additional monitors and cameras are not paired by default. See *Pairing Additional Monitors or Cameras* on pg. 14.

**Table of Contents**

Introduction.....	1	Programming and Using the	
Parts List.....	2	On-Screen Display.....	9~10
Specifications .....	3	Programming the Advanced Settings .....	10~11
Overview.....	4	Operating the Wireless Video Door Phone .....	12~13
Display Overview.....	5	Resetting the Camera and	
Installation Notes.....	5	Pairing a First Monitor .....	13
Camera Wiring Diagram.....	6	Pairing Additional Monitors or Cameras .....	14
Sample Application.....	6	Tamper Alarm .....	15
Installation – Camera .....	7	Troubleshooting .....	15
Installation – Monitor .....	7~8	Accessories.....	16
On-Screen Display Features.....	8	Warranty and Notices.....	16

**Specifications**

Camera	
Type	Color camera
Chip	CMOS
Resolution	640 TV Lines
Lens	2mm
Field of view	170°
Camera angle adjustment	Up to 20° any direction
Operating voltage	9~16 VAC/5~16 VDC
Relock delay	3/6/8 Seconds
Relay output	3A@24VAC/24VDC
Current draw	Active 300mA@12VDC Standby 15mA@12VDC
Battery life	Active ~7 Hours Standby ~60 Days
IR LED Range	5' (1.5m)
IR LED Frequency	940nm
PIR Detection range	9' (3m)
PIR Detection angle	60°
Dimensions (with bracket)	3 1/8" x 5 11/16" x 1 15/16" (80x144x50 mm)
Weight	4.3-oz (122g)
Operating temperature	14°~122° F (-10°~50° C)

Monitor	
Display	7" (178mm) TFT
Operating voltage	12VDC (adapter) or 3.7VDC (battery)
Current draw	Active 600mA@3.7VDC Standby 5mA@3.7VDC
Battery life	Active ~2.5 Hours Standby ~7 days
Antenna gain	0dBi
Modulation type	GFSK
Operating frequency	2402~2480MHz
RF power	120mW
Wireless range	492' (150m)*
Operating temperature	32°~95° F (-5°~35° C)
Dimensions	8"x6"x1 1/8" (203x153x27 mm)
Weight	1.2-lbs (544g)

\*Line-of-sight range. Actual range may vary depending on the installation and operating environment

## Overview

### Camera

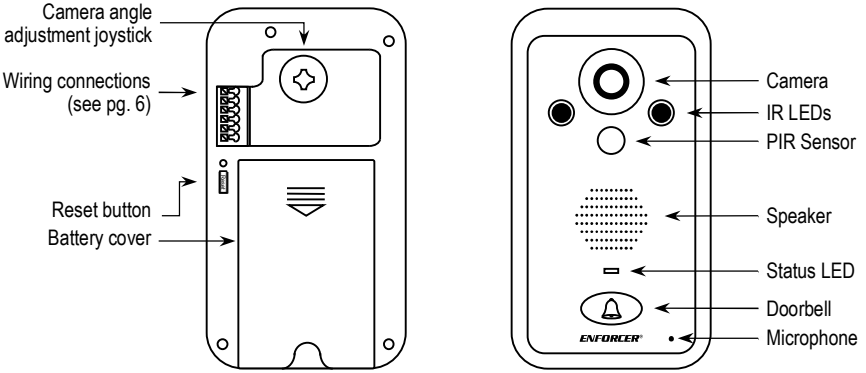

### Monitor

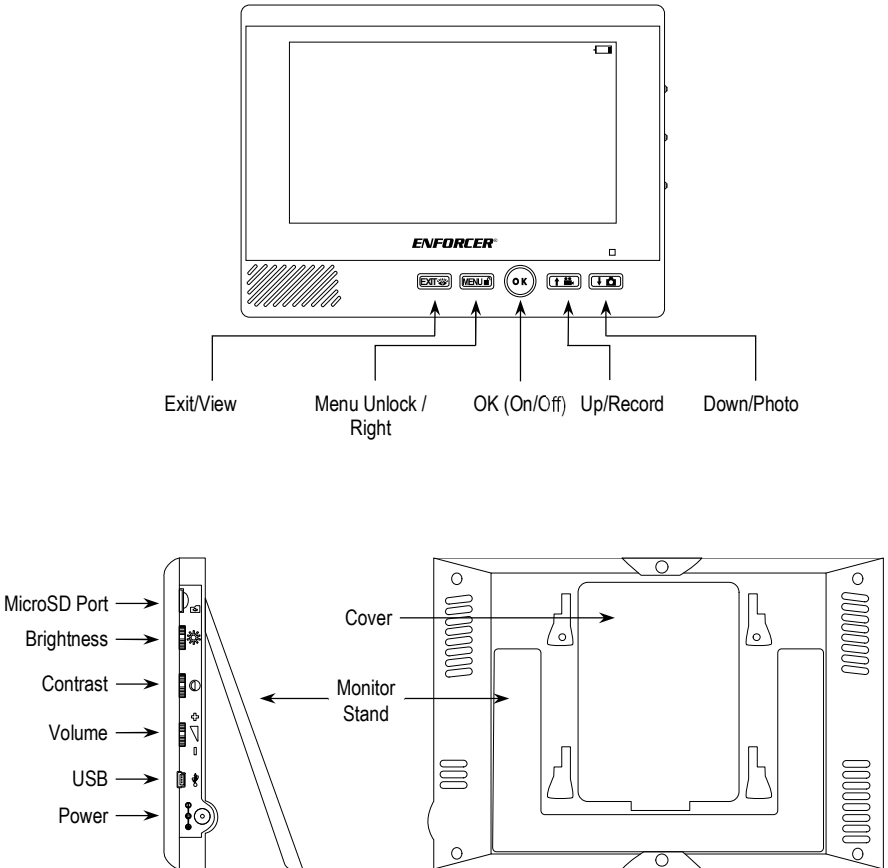

## Display Overview



- 1** : ID – Displays the monitor ID number
- ||||| : Signal Strength – Displays the wireless signal strength
- 🔔 : Communication Mode – Displays current communication mode
  - 🔔 – Bell indicates an incoming call
  - 🔇 – Crossed out microphone indicates one-way communication
  - 🎤 – Microphone indicates two-way communication
- 📧 : Message – Displays when there is a message due to a missed call
- 👤 : PIR – Displays when the PIR sensor is turned on
- 📷 : Photo – Displays when a photo is taken
- 🔒 : Relay – Displays while the relay is active
- 💣 : Alarm – Displays when the tamper alarm has been activated
- 📶 : Monitor volume – Displays the current monitor volume
- 🔋 : Monitor Battery: Displays the current monitor station battery level
- 🔋 : Camera Battery: Displays the current camera station battery level

## Installation Notes

1. Unpack the video door phone and note the included parts.
2. Read this manual thoroughly. A clear understanding of the manual will make installation and operation much easier.
3. Find a location to mount the monitor and camera. Approximately 5ft (1.5m) above the ground is optimal, where the visitor would stand approximately 2.5~5 ft (0.8~1.5 m) from the camera.

**NOTE:** The camera tilt and pan angle can be adjusted up to 20° from centerline to compensate for less-than-optimal situations (see below).

4. Avoid mounting the camera or monitor near sources of strong electromagnetic signals or other electronic devices that may cause interference.
5. Avoid mounting the camera in direct sunlight or exposing the camera to strong vibrations, direct rain, or moisture, which could result in damage to the camera. Strong backlight or reflection may degrade the resulting video image.
6. The monitor and camera contain no user-serviceable parts. Opening them may damage sensitive components and will void the warranty.

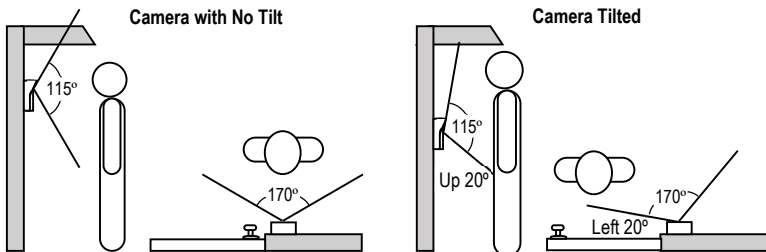

**Camera Wiring Diagram**

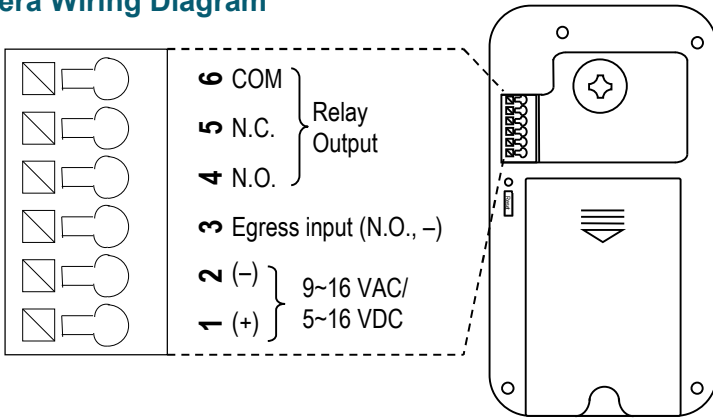

1. Positive (+) power input – Connect to the red wire of the included AC adapter or to the positive wire of the doorbell's power supply.
2. Negative (-) power input – Connect to the black wire of the included AC adapter or to the negative wire of the doorbell's power supply.
3. Egress (N.O.) negative input – Connect to an optional N.O. egress device. The egress device will activate the relay for the same length as the lock delay. (See *Unlocking Duration* in *Programming the Advanced Settings*, pg. 10).
4. N.O. (Normally opened) output – Wire to the lock device for fail-secure operation.
5. N.C. (Normally closed) output – Wire to the lock device for fail-safe operation.
6. Common output – Wire to the power supply of the lock device.

**NOTE:** For 16VAC doorbell installation, wire directly from the doorbell's transformer.

**Sample Application**

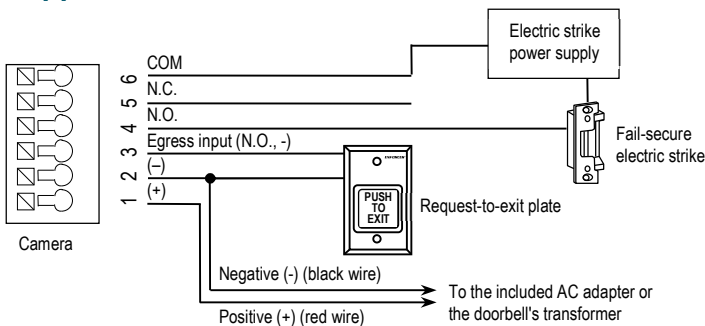

- The camera is connected to its included AC adapter.
- The egress input is connected to a Request-to-Exit Plate. The homeowner can exit the premises by pressing this button.
- The N.O. (normally open) output is wired to an electric lock. The camera and the Request-to-Exit Plate both activate the strike, allowing entry or egress.
- The electric lock's power supply is wired to the COM (common) output.

## Installation – Camera

1. Position the camera so the area to be monitored is easily visible, optimally 5ft (1.5m) above the ground. Do not position the camera in direct sunlight, or where it will be exposed directly to rain or snow.

**NOTE:** For best results, the visitor should stand 2.5~5 ft (0.8~1.5 m) away from the camera.

2. Cut a hole large enough to run the min. 21AWG 2-conductor wire to the door unlock device through the wall, as well as to the included power supply.

3. Mount the camera bracket to the wall with three screws. Use screw anchors if the bracket is mounted on drywall or brick.

4. Run the 2-conductor wire from the camera, through the wire hole in the bracket, to the optional door unlock device.

5. Install the rechargeable lithium-ion battery into the camera. The battery will act as a backup power source in case of a power outage.

6. Connect the AC adapter (see *Camera Wiring Diagram*, pg. 6).

7. Install the monitor battery (see below) and turn on the camera and monitor. If the camera is not in the bracket, the tamper alarm will sound. Press the "OK" button on the monitor repeatedly to disable the tamper alarm.

8. Experiment with the camera angle using the joystick on the back of the camera to adjust the direction of the camera while viewing the image on the monitor.

9. Mount the camera into the bracket:

- Push the top of the camera into the top of the bracket.
- Push the bottom of the camera into the bottom of the bracket.
- Screw in the bottom of the camera to fix the camera into the bracket and push the plastic screw cover into the bottom of the bracket, over the screw.

**NOTE:** Do not block the PIR sensor on the camera.

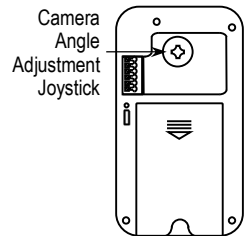
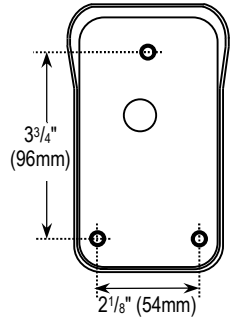
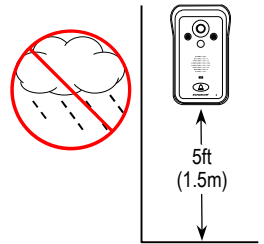

## Installation – Monitor

### Installing the Monitor Battery

Remove the battery cover on the back of the monitor and insert the included DP-266-BM7 lithium-ion battery.

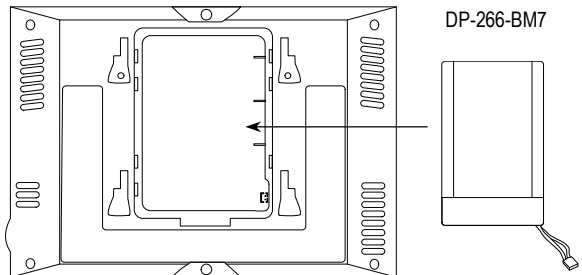

## Installation – Monitor (Continued)

### Monitor Bracket

Mount the monitor bracket to the wall with four screws. Use screw anchors if the bracket is mounted on drywall or brick.

### Turning the Monitor ON

Hold the "ON/OFF" button for 3 seconds. The monitor will turn ON with the ENFORCER screen.

### Standby Mode

If the display is off, press the "ON/OFF" button momentarily to leave standby mode and turn the display ON. The red indicator LED will flash once every three seconds in standby mode.

### Low Battery

When the battery is low (indicated by 1 or 0 bars on the display's battery icon), the red indicator LED will start to flash once per second.

### Turning the Monitor OFF

While the monitor's display is ON, hold the "ON/OFF" button for 3 seconds and the Shutdown menu will come up. Select "YES" to turn the monitor "OFF".

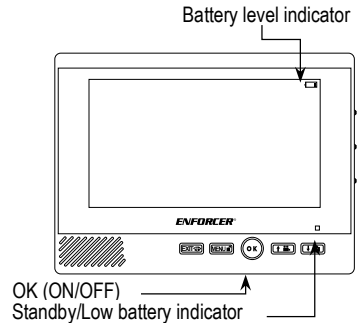
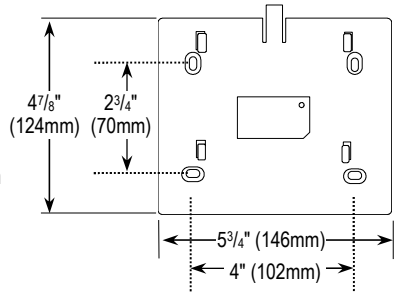

## On-Screen Display Features



**Photos** – View and delete photos taken by the camera station. There are four different types of photos

**M** – Photos taken by the user manually (1 photo taken).

**A** – Photos taken by the camera station automatically when the doorbell button is pressed (1 photo taken).

**T** – Photos taken by the camera station automatically when the unit is removed from the bracket and the tamper alarm activates (4 photos taken).

**P** – Photos taken by the camera station automatically when the PIR function is activated (3 photos taken).



**Messages** – View photos from missed calls, same as "Automatic" photos.



**Time** – Set the time and date.



**Ring** – Choose from four different ring tones (Telephone, Doorbell, Für Elise, or Jingle Bells) and set ring volume.



**Video** – View and delete videos taken by the camera station.



**Setup** – Set advanced settings such as Motion detection, Backlight time, Unlocking duration, Pairing, Alarm settings, or Version information.



## Programming and Using the On-Screen Display

1. While the monitor display is on, press the "Menu/Unlock" button to open the on-screen display.
2. Use the "Up" and "Down" buttons to move the cursor up or down. Use the "Menu/Unlock" button to move the cursor to the right.
3. To select a Menu option, highlight the option and press the "OK" button.
4. To exit the on-screen display, press the "Exit" button.

**NOTE:** If there is no activity, the monitor will exit programming mode and the display will turn off in 35 seconds.

## Viewing and Deleting Photos

1. While the monitor display is on, press the "Menu/Unlock" button to open the on-screen display.
2. Highlight the "Photo" icon and press the "OK" button to enter the "Photo" screen.
3. Use the "Up" and "Down" buttons to select the photo to be viewed.

**NOTE:** Photos are saved with the following format: "X-HHMMSS-YYMMDD.jpg" with "X" being the type of photo, "HHMMSS" being the time the photo was taken, and "YYMMDD" being the date the photo was taken.

4. Press the "OK" button and select from "View," "Delete," or "Delete All."
  - a. Press "View" to view a photo.
  - b. Press "Delete" to delete the selected photo (after an additional prompt).
  - c. Press "Delete All" to delete all photos (after an additional prompt).
5. Once viewing a photo, press the "Up" or "Down" buttons to cycle through other photos.
6. Press the "OK" button to either delete or exit the photo viewing mode and go back to the on-screen display menu.

### NOTES:

- The monitor can save up to 240 photos. Photos are saved in a "first-in, first-out" method, meaning that the system automatically deletes the oldest photo.
- There is no way to export any of the photos on the device.

## Viewing and Deleting Messages

1. While the monitor display is on, press the "Menu/Unlock" button to open the on-screen display.
2. Highlight the "Messages" icon and press the "OK" button to enter the "Messages" screen.
3. Use the "Up" and "Down" buttons to select the message to be viewed.

**NOTE:** Messages are the same as Automatic photos but are saved with the following format: "HH:MM:SS MM-DD-YYYY."

4. Press the "OK" button and select from "Open," "Delete," or "Delete All."
  - a. Press "Open" to view a message.
  - b. Press "Delete" to delete the selected message (after an additional prompt).
  - c. Press "Delete All" to delete all messages (after an additional prompt).
5. Once viewing a message, press the "OK" button to return to the "Messages" screen.

### NOTES:

- The monitor can save up to 10 messages. Messages are saved in a "first-in, first-out" method, meaning that the system automatically deletes the oldest message.
- Messages will not be saved if the indoor monitor is off.

## Programming and Using the On-screen Display (Continued)

### Programming the Time and Date

1. While the monitor display is on, press the "Menu/Unlock" button to open the on-screen display.
2. Highlight the "Time" icon and press the "OK" button to enter the "Time" screen.
3. Use the "Up" and "Down" buttons to adjust the value. Use the "Menu/Unlock" button to move to the next value.
4. Press the "OK" button when finished programming to go back to the on-screen display menu.

**NOTE:** The time is set in 24-hour time format.

### Programming the Ringer

1. While the monitor display is on, press the "Menu/Unlock" button to open the on-screen display.
2. Highlight the "Ring" icon and press the "OK" button to enter the "Ring" screen.
3. Use the "Up" and "Down" buttons to select one of four ring tones: Telephone (default), Doorbell, Für Elise, or Jingle Bells.
4. Press the "OK" button when finished programming to go back to the on-screen display menu.

### Programming the Language

1. While the monitor display is on, press the "Menu/Unlock" button to open the on-screen display.
2. Highlight the "Language" icon and press the "OK" button to enter the "Language" screen.
3. Use the "Up" and "Down" buttons to select a language: English (default), German, Spanish, French, Russian, or Chinese.
4. Press the "OK" button when finished programming to go back to the on-screen display menu.

---

## Programming the Advanced Settings

1. While the monitor display is on, press the "Menu/Unlock" button to open the on-screen display.
2. Highlight the "Setup" icon and press the "OK" button to enter the "Setup" screen.
3. Use the "Up" and "Down" buttons to select the advanced settings menu.
4. Press the "OK" button to enter the selected advanced settings menu.

### Monitor Detection

1. Select "Motion Detection" and press the "OK" button.
  2. Select "Off" or "On" to turn the PIR function off or on and press the "OK" button.
- NOTE:** If multiple cameras are paired to the monitor, then select the desired camera.
3. The monitor will connect to the desired camera.
  4. Press the "OK" button to confirm.

**NOTE:** A single beep from the camera indicates motion detection has been turned OFF.  
A triple beep indicates motion detection has been turned ON.

### Backlight Time

1. Select "Backlight Time" and press the "OK" button.
2. Use the "Up" or "Down" buttons to select a backlight time between 10~60 seconds.
3. Press the "OK" button to confirm.

## Programming the Advanced Settings (Continued)

### Unlocking Duration

1. Select "Unlocking Duration" and press the "OK" button.
2. Select from 3, 6, or 8 seconds and press the "OK" button.  
**NOTE:** If multiple cameras are paired to the monitor, then select the desired camera.
3. The monitor will connect to the desired camera.
4. Press the "OK" button to confirm.  
**NOTE:** A single beep from the camera indicates 3 seconds, a double beep indicates 6 seconds, and a triple beep indicates 8 seconds.

### Pairing

See *Resetting the Camera and Pairing a First Monitor and Programming Additional Monitors or Cameras* on pgs. 13~14 for information regarding the "Pairing" setting.

### Alarm Setting

1. Select "Alarm setting" and press the "OK" button.
2. Select "On" or "Off" to turn the tamper alarm on or off and press the "OK" button.  
**NOTE:** If multiple cameras are paired to the monitor, then select the desired camera.
3. The monitor will connect to the desired camera.
4. Press the "OK" button to confirm.  
**NOTE:** A single beep from the camera indicates the tamper alarm has been turned OFF.  
A double beep indicates the tamper alarm has been turned ON.

### Version

1. Select "Version" and press the "OK" button.
2. View the version number.

## Operating the Wireless Video Door Phone

### Communicating with the Camera

#### Request entry

1. Press the doorbell button on the camera. The indoor monitor will ring and display an image from the camera. The monitor will also display a bell icon.
2. Wait for the indoor user to accept the call and activate the onboard relay as necessary

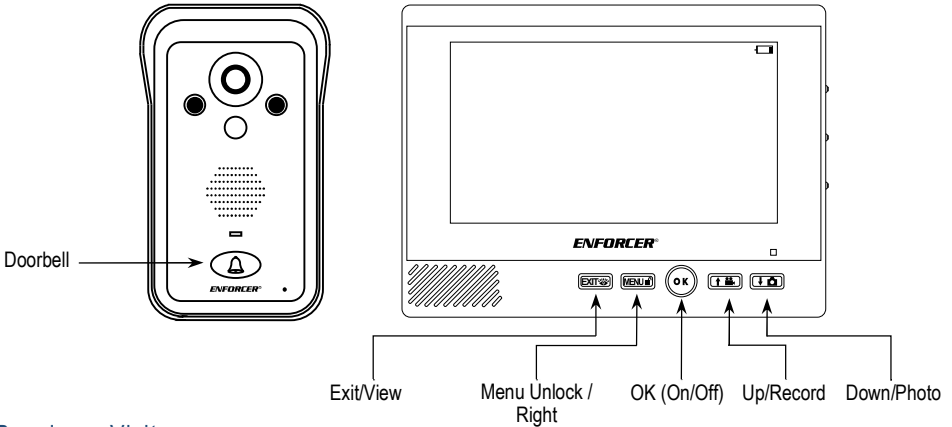

#### Receive a Visitor

1. If a visitor presses the doorbell button on the camera, the monitor's display turns ON and the monitor sounds the chosen ring tone.
2. Press the "OK" button to accept the call. The bell icon will change to a microphone icon.
3. Press the "Menu/Unlock" button on the monitor to activate the camera's onboard relay.
4. Press the "Exit/View" button to mute the monitor (the camera station can still be heard on the indoor monitor).
5. Press the "Down/Photo" button on the monitor to take a manual photo.
6. Press the "Volume up/down" button to adjust the audio level.
7. Press the "OK" button when finished with the call.

#### View and/or Talk to a Visitor Who Has Not Pressed the Camera Doorbell Button

1. Press the "OK" or "Power" button to turn the monitor's display ON.
2. Press the "Exit/View" button to monitor the camera station.  
**NOTE:** If multiple cameras are connected, then use the "Up" or "Down" button to select the desired camera station to monitor. Press "OK" to connect to the selected camera.
3. The user can now view and hear the camera station. The microphone icon will have an "X" through it.
4. Press the "Exit/View" button to activate two-way communication. The microphone's "X" will be removed.
5. To unlock the optional electronic door lock, press the "Menu/Unlock" button to activate the relay.
6. Press the "Down/Photo" button to take a manual photo.
7. Press the "OK" button when finished with the call.

---

## Operating the Wireless Video Door Phone (Continued)

### Communicating between Monitors

**NOTE:** The Wireless Video Door Phone system can be set up with up to 2 cameras and 3 monitors. If multiple monitors are set up, then the system can be used as an intercom between each monitor. To pair additional monitors, see *Pairing Additional Monitors or Cameras*, pg. 14.

#### Intercom Feature with Two Monitors:

1. Make sure both monitors are powered ON.
2. Press the "OK" or "Power" button to turn the monitor's display on.
3. Press the "OK" button to call the other monitor.
4. To accept the call, the other monitor's user must press their "OK" button.
5. Press the "OK" button again when finished with the call.

**NOTE:** The intercom feature will automatically timeout after 60 seconds

#### Intercom Feature with Three Monitors

1. Make sure all monitors are powered ON.
2. Press the "OK" or "Power" button to turn the monitor's display on.  
**NOTE:** Each paired monitor will have an identification number in the top left corner (1, 2, or 3).
3. Press the "Up" button to call the next highest ID monitor.
4. Press the "Down" button to call the next lowest ID monitor.
  - If monitor 1 is calling monitor 2, the user would press the "Up" button.
  - If monitor 3 is calling monitor 2, the user would press the "Down" button.
  - If monitor 3 is calling monitor 1, the user would press the "Up" button.
5. Press the "OK" button when finished with the call.

---

## Resetting the Camera and Pairing a First Monitor

**NOTE:** By default, the monitor in the DP-266-1C7Q Complete Kit is paired with the camera. These instructions apply to resetting the camera and monitor system.

1. Put the camera into pairing mode:
  - a. Remove the camera from the bracket.
  - b. If the tamper alarm is active, then the alarm will begin to sound.
    - i. Disconnect power from the camera by removing the battery and disconnecting the power wiring.
    - ii. Replace the battery.
  - c. Use a paper clip or other small object to press and hold the camera's reset button for three to four seconds. A single beep indicates the camera is in pairing mode.

**NOTE:** The camera will remain in pairing mode for ~15 seconds before automatically exiting.

2. Pair the first monitor to the camera:
  - a. Select "Match code" from the "Pairing" option in the "Settings" menu.
  - b. The monitor will display "Success" and the monitor and camera will beep three times.
3. Reconnect the power wires and return the camera to the bracket.
4. Press the doorbell button on the camera to confirm the connection.

## Pairing Additional Monitors or Cameras

**NOTE:** By default, the monitor in the DP-266-1C7Q Complete Kit is paired with the camera. These instructions apply to pairing a second or third monitor, or a second camera.

### To Pair an Additional Monitor

1. Put the first monitor into pairing mode:
  - a. Select "Give code" from the "Pairing" option in the "Settings" menu.
2. Put the second monitor in pairing mode:
  - a. Select "Receive code" from the "Pairing" option in the "Settings" menu.
  - b. The second monitor will display "Success" and beep three times.  
**NOTE:** The first monitor will timeout automatically after ~20 seconds.
  - c. Press "Exit" on the first monitor to exit pairing mode.
3. Press the doorbell button on the camera to test the connection.
  - a. Answer the call from the newly paired monitor to confirm the connection.
4. To pair a third monitor, use the second monitor to "Give Code".

### NOTES

Up to three total monitors can be learned to the system.

The intercom feature will not function until the connection is confirmed by the new monitor.

### To Pair an Additional Camera

1. Put the camera into pairing mode:
  - a. Remove the camera from the bracket.
  - b. If the tamper alarm is active, then the alarm will begin to sound.
    - i. Disconnect power from the camera by removing the battery and disconnecting the power wiring.
    - ii. Replace the battery.
  - c. Use a paper clip or other small object to press and hold the camera's reset button for seven to eight seconds. The camera will beep once around four seconds and twice around eight seconds.

**NOTE:** The camera will remain in pairing mode for ~15 seconds before automatically exiting.

2. Put any monitor in the system into pairing mode:
  - a. Select "Give Code" from the "Pairing" option in the "Settings" menu.
3. The camera will beep three times to indicate successful pairing.
4. Press "Exit" on the monitor to exit pairing mode.
5. Reconnect the power wires and return the camera to the bracket.
6. Press the doorbell button on the camera to confirm the connection.

## Tamper Alarm

The tamper alarm activates anytime the camera is removed from the bracket, warning the user of possible vandalism. The tamper alarm will sound on the camera and any connected monitors.

1. To disable the tamper alarm if no monitors are paired with the camera:
  - a. Return the camera to the bracket.
  - b. If the alarm persists, unplug the camera and remove the battery.
  - c. Return the camera's battery and reconnect it to power.
2. To disable the tamper alarm if one or more monitors are paired with the camera:
  - a. Repeatedly press the "OK" button on all paired monitors.
  - b. If the alarm persists, unplug the camera and remove the battery.
  - c. Unplug each monitor and remove each monitor's battery.
  - d. Return the camera's battery and reconnect it to power.
  - e. Insert each monitor's battery and reconnect each monitor to power.
3. To permanently disable the tamper alarm, see *Alarm Setting in Programming the Advanced Settings*, pg. 11.

## Troubleshooting

The monitor's screen is blank	<ul style="list-style-type: none"> <li>• Make sure the "ON/OFF" or "OK" button was pressed to wake the monitor</li> <li>• Make sure the monitor's battery is charged</li> <li>• Plug the charger directly into the monitor</li> </ul>
The monitor is not charging	<ul style="list-style-type: none"> <li>• Remove the battery from the battery compartment and clean both the battery contacts and the monitor's connection contacts</li> <li>• Make sure the kickstand is extended when placing in the charger stand</li> <li>• Make sure the power adapter is correctly connected to the charger stand</li> <li>• Connect the power adapter directly to the monitor</li> </ul>
The monitor does not ring	<ul style="list-style-type: none"> <li>• Check that the volume is turned up</li> <li>• Check that the monitor is in standby mode</li> <li>• Check that the monitor is placed in the mounting bracket</li> </ul>
The monitor cannot connect to the camera	<ul style="list-style-type: none"> <li>• Check that the monitor has been paired with the camera</li> <li>• Check that the monitor is within range of the camera</li> </ul>
The monitor's screen image quality is poor	<ul style="list-style-type: none"> <li>• Adjust the monitor's display brightness</li> <li>• Clean the camera's lens using a soft, clean cloth</li> <li>• Change the position of the camera</li> <li>• Move the monitor away from potential sources of interference (microwaves, television, lamps, etc.)</li> </ul>
The monitor is unable to activate the camera's relay	<ul style="list-style-type: none"> <li>• Make sure the user is pressing the "Menu/Unlock" button when in two-way communication (the microphone icon is lit and does not have an "X" through it)</li> <li>• Check the wiring between the camera and the optional door locking device</li> </ul>

## Accessories

### Additional Monitor



DP-266-M7Q

### Additional Camera



DP-266-CAQ

### Replacement Rechargeable Lithium-Ion Battery for Monitor



DP-266-BM7

### Replacement Rechargeable Lithium-Ion Battery for Camera



DP-266-BC7

#### FCC COMPLIANCE STATEMENT

FCC ID: ERY-DP2661C7Q

THIS DEVICE COMPLIES WITH PART 15 OF THE FCC RULES. OPERATION IS SUBJECT TO THE FOLLOWING TWO CONDITIONS: (1) THIS DEVICE MAY NOT CAUSE HARMFUL INTERFERENCE AND (2) THIS DEVICE MUST ACCEPT ANY INTERFERENCE RECEIVED, INCLUDING INTERFERENCE THAT MAY CAUSE UNDESIRABLE OPERATION.

Notice: The changes or modifications not expressly approved by the party responsible for compliance could void the user's authority to operate the equipment.

**IMPORTANT NOTE:** To comply with the FCC RF exposure compliance requirements, no change to the antenna or the device is permitted. Any change to the antenna or the device could result in the device exceeding the RF exposure requirements and void user's authority to operate the device.

**IMPORTANT:** Users and installers of this product are responsible for ensuring this product complies with all national, state, and local laws and statutes related to monitoring and recording audio and video signals. SECO-LARM will not be held responsible for the use of this product in violation of any current laws or statutes.

**IMPORTANT:** Users and installers of this product are responsible for ensuring that the installation and configuration of this product complies with all national, state, and local laws and codes. SECO-LARM will not be held responsible for the use of this product in violation of any current laws or codes.

**California Proposition 65 Warning:** These products may contain chemicals which are known to the State of California to cause cancer and birth defects or other reproductive harm. For more information, go to [www.P65Warnings.ca.gov](http://www.P65Warnings.ca.gov).

**WARRANTY:** This SECO-LARM product is warranted against defects in material and workmanship while used in normal service for one (1) year from the date of sale to the original customer. SECO-LARM's obligation is limited to the repair or replacement of any defective part if the unit is returned, transportation prepaid, to SECO-LARM. This Warranty is void if damage is caused by or attributed to acts of God, physical or electrical misuse or abuse, neglect, repair or alteration, improper or abnormal usage, or faulty installation, or if for any other reason SECO-LARM determines that such equipment is not operating properly as a result of causes other than defects in material and workmanship. The sole obligation of SECO-LARM and the purchaser's exclusive remedy, shall be limited to the replacement or repair only, at SECO-LARM's option. In no event shall SECO-LARM be liable for any special, collateral, incidental, or consequential personal or property damage of any kind to the purchaser or anyone else.

**NOTICE:** The SECO-LARM policy is one of continual development and improvement. For that reason, SECO LARM reserves the right to change specifications without notice. SECO-LARM is also not responsible for misprints. All trademarks are the property of SECO-LARM U.S.A., Inc. or their respective owners. Copyright © 2022 SECO-LARM U.S.A., Inc. All rights reserved.

## SECO-LARM® U.S.A., Inc.

16842 Millikan Avenue, Irvine, CA 92606  
Phone: (949) 261-2999 | (800) 662-0800

Website: [www.seco-larm.com](http://www.seco-larm.com)  
Email: [sales@seco-larm.com](mailto:sales@seco-larm.com)

