

ENFORCER®

DP-236Q Wireless Video Door Phone Manual



- Wireless operation – camera and monitor can operate from up to 492ft (150m)² away
- Remotely and securely talk to visitors and unlock doors or gates via the monitor
- Lightweight monitor can be carried around the premises while talking to the visitor
- Connect up to two additional monitors¹
- Camera includes a built-in PIR sensor that activates the camera and takes photos of the visitor when he or she approaches
- Camera has built-in IR LEDs for nighttime operation
- Monitor includes a kickstand and a charging base
- Camera powered by 9~16 VAC/5~16 VDC
- Monitor front door at any time
- Egress input
- 170° wide field of view
- Adjustable camera pan and tilt angle—up to 20° from centerline in any direction—to allow for mounting variations

¹Second and third monitors sold separately.

²Line-of-sight range. Actual range may vary depending on the installation and operating environment.

Table of Contents:

| | | | |
|-----------------------------|---|-----------------------------------|------|
| Introduction | 2 | Installation – Monitor | 6-7 |
| Parts List | 2 | Programming | 8 |
| Also Available | 2 | Operating the Wireless | |
| Specifications | 3 | Video Door Phone | 9-10 |
| Overview | 3 | Pairing Additional Monitors | 10 |
| Display Overview | 4 | Resetting the Camera | |
| Installation Notes | 4 | and Pairing a First Monitor | 11 |
| Camera Wiring Diagram | 5 | Tamper Alarm | 11 |
| Sample Application | 5 | Troubleshooting | 12 |
| Installation – Camera | 6 | Warranty | 12 |

Introduction:

The ENFORCER Wireless Video Door Phone is the convenient and secure way to monitor and control an entryway such as a door or gate from nearly 492 feet (150 meters) away.

When a guest or visitor presses the doorbell button on the camera unit, the homeowner can use one of up to three lightweight wireless LCD monitors to see who is requesting entry, speak with the caller, take a photo, and decide whether or not to grant entry.

Parts List:

DP-236Q

Complete Kit

- 1x Monitor (DP-236-MQ)¹
- 1x Camera (DP-236-CQ)¹
- 1x Monitor charger stand
- 1x Monitor kick stand
- 1x AC Power adapter with USB port (for monitor)
- 1x USB Cable (for monitor)
- 2x Rechargeable lithium ion batteries (for monitor and camera)
- 1x AC Power adapter with DC plug (for camera)
- 1x DC Jack with pigtail (for camera)
- 5x Mounting screws
- 5x Screw anchors
- 2x Camera screw
- 1x Screw cover

¹ By default, the monitor in the DP-236Q Complete Kit is paired with the camera.



DP-236-MQ

Additional Monitor Unit

- 1x Monitor²
- 1x Monitor charger stand
- 1x Monitor kick stand
- 1x AC Power adapter with USB port (for monitor)
- 1x USB Cable
- 1x Rechargeable lithium ion battery



Also Available:

DP-236-SQ

Replacement Monitor Charger Stand

DP-236-BQ

Replacement Battery

² Additional monitors are not automatically paired with the camera. See pg. 10, Pairing Additional Monitors.

Specifications:

| Camera | | |
|---------------------------|-----------------------------------------------------------------------------------------------------------------------|---------------------|
| Type | Color Camera | |
| Chip | CMOS | |
| Resolution | 480 TV Lines | |
| Lens | 2mm | |
| Field of view | 170° | |
| Camera angle adjustment | Up to 20° any direction | |
| Operating voltage | 9~16 VAC/5~16 VDC | |
| Relock delay | 1~6 s | |
| Relay output | 3A@250VAC/30VDC | |
| Current draw | Active | 250mA@4.2VDC |
| | Standby | 3mA@4.2VDC |
| Battery life | Active | 4.4 Hours |
| | Standby | 366 Hours (15 days) |
| PIR Detection range | 9' (3m) | |
| PIR Detection angle | 138° | |
| Dimensions (with bracket) | 5 ¹¹ / ₁₆ "x3 ¹ / ₈ "x1 ¹⁵ / ₁₆ " (144x80x50 mm) | |
| Weight | 4.3-oz (122g) | |
| Operating temperature | 14°~122° F (-10°~50° C) | |

| Monitor | | |
|-----------------------|--------------------------------------------------------------------------------------|--------------------|
| Display | 3 ³ / ₈ " (86mm) TFT | |
| Operating voltage | 5VDC (adapter) or 3.7VDC (battery) | |
| Current draw | Active | 250mA@4.2VDC |
| | Standby | 5mA@4.2VDC |
| Battery life | Active | 4.4 Hours |
| | Standby | 220 Hours (9 days) |
| Operating frequency | 2410.875~2471.625MHz | |
| RF power | 120mW | |
| Wireless range | 492' (150m)* | |
| Dimensions | 5"x3 ³ / ₈ "x1 ¹ / ₈ " (127x85x22 mm) | |
| Weight | 3.9-oz (110g) | |
| Operating temperature | 32°~104° F (0°~40° C) | |

*Line-of-sight range. Actual range may vary depending on the installation and operating environment.

Overview:

Camera

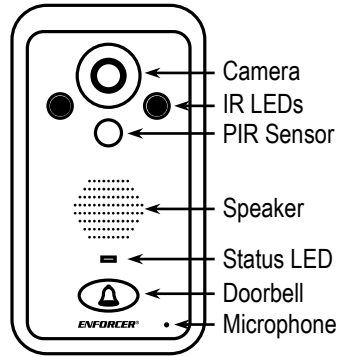
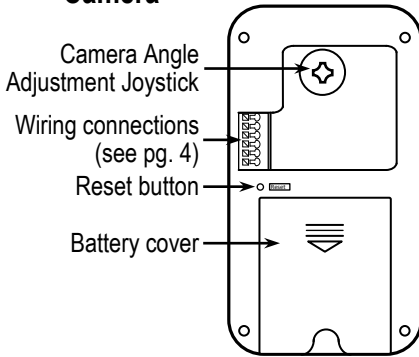

Monitor

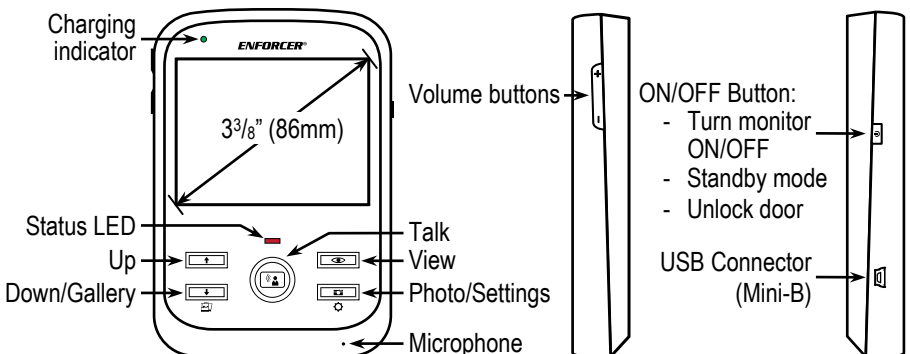



Display Overview:





 : Signal Strength – Displays the wireless signal strength

12:00:00 : Time – Displays the current time

 : PIR – Displays when the PIR sensor is turned on

 : Ringer – Displays if the ringer is audible or muted

 : Missed Call – Displays when there is a missed call

 : Two-Way Communication – Displays when the monitor and camera station can hear each other

 : Relay – Displays while the relay is active

 : Camera Battery: Displays the current camera station battery level

 : Monitor Battery: Displays the current monitor station battery level

Installation Notes:

1. Unpack the video door phone and note the included parts.
2. Read this manual thoroughly. A clear understanding of the manual will make installation and operation much easier.
3. Find a good location to mount the monitor and camera. Approximately 5ft (1.5m) above the ground is optimal, where the visitor would stand approximately 2.5~5ft (0.8~1.5m) from the camera. Note that the camera tilt and pan angle can be adjusted up to 20° from centerline to compensate for less than optimal situations (see below).
4. Avoid mounting the camera or monitor near sources of strong electromagnetic signals or other electronic devices that may cause interference.
5. Avoid mounting the camera in direct sunlight or exposing the camera to strong vibrations, direct rain, or moisture, which could result in damage to the camera. Strong backlight or reflection may degrade the resulting video image.
6. The monitor and camera contain no user-serviceable parts. Opening them may damage sensitive components and will void the warranty.

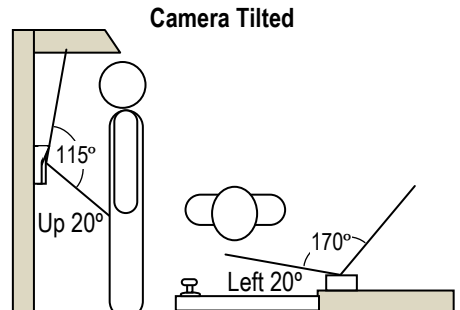
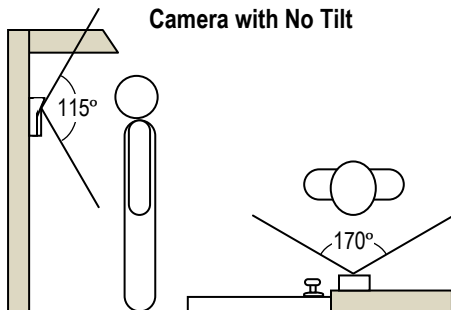

Camera Wiring Diagram:

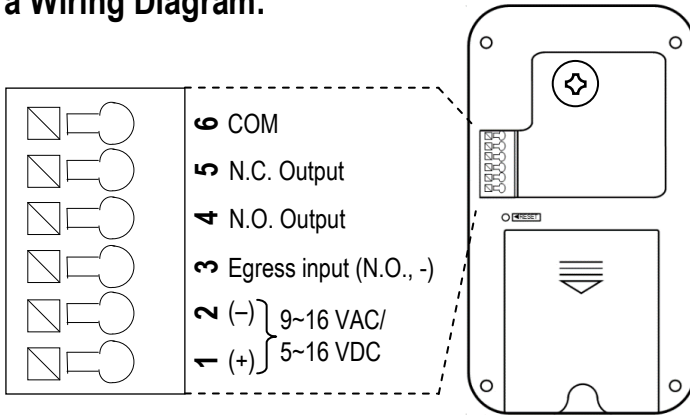

- 1) Positive (+) power input. Connect to the red wire of the included AC adapter or to the positive wire of the doorbell's power supply.
- 2) Negative (-) power input. Connect to the black wire of the included AC adapter or to the negative wire of the doorbell's power supply.
- 3) Egress (N.O.) negative input. Connect to an optional N.O. egress device. The egress device will activate the relay for the same length as the lock delay. (See pg. 8, Programming the lock delay).
- 4) N.O. (Normally opened) output. Wire to the lock device for fail-secure operation.
- 5) N.C. (Normally closed) output. Wire to the lock device for fail-safe operation.
- 6) Common output. Wire to the power supply of the lock device.

NOTE: For 16VAC doorbell installation, wire directly from the doorbell's transformer.

Sample Application:

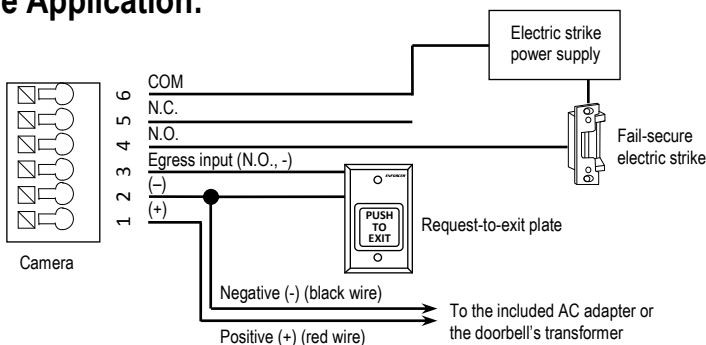

- The camera is connected to its included AC adapter.
- The egress input is connected to a Request-to-Exit Plate. The homeowner can exit the premises by pressing this button.
- The N.O. (normally open) output is wired to an electric lock. The camera and the Request-to-Exit Plate both activate the strike, allowing entry or egress.
- The electric lock's power supply is wired to the COM (common) output.

Installation – Camera:

1. Position the camera so the area to be monitored is easily visible, optimally 5ft (1.5m) above the ground. Do not position the camera in direct sunlight, or where it will be exposed directly to rain or snow.
NOTE: For best results, the visitor should stand 2.5~5ft (0.8~1.5m) away from camera.
2. Cut a hole large enough to run the min. 21AWG 2-conductor wire to the door unlock device through the wall, as well as to the included power supply.
3. Install the camera bracket to the wall with three screws. Use screw anchors if the bracket is mounted on drywall or brick.
4. Run the 2-conductor wire from the camera through the wire hole in the bracket to the optional door unlock device.
5. Install the rechargeable lithium ion battery into the camera. The battery will act as a backup power source in case of a power outage.
6. Connect the AC adapter (see Camera Wiring Diagram on pg. 5).
7. Install the monitor battery (see below) and turn on the camera and monitor. If the camera is not in the bracket, the tamper alarm will sound. Press the "Talk" button on the monitor repeatedly to disable the tamper alarm.
8. Experiment with the camera angle using the joystick on the camera back to adjust the direction of the camera while viewing the image on the monitor.
9. Mount the camera into the bracket:
 - o Push the top of the camera into the top of the bracket.
 - o Push the bottom of the camera into the bottom of the bracket.
 - o Screw in the bottom of the camera to fix the camera into the bracket and push the plastic screw cover into the bottom of the bracket, over the screw.

NOTE: Do not block the PIR sensor on the camera.

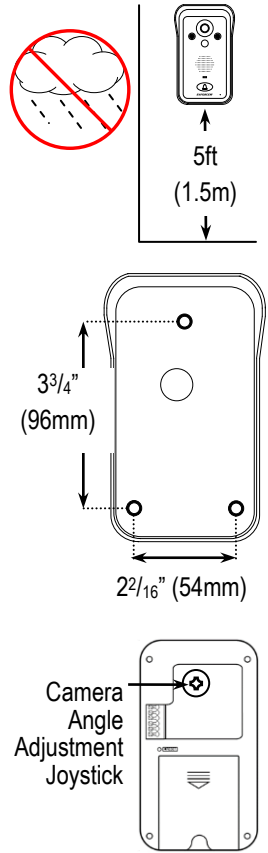

Installation – Monitor:

Install the monitor battery:

Remove the battery cover on the back of the monitor and insert the included BP-6M lithium ion battery.

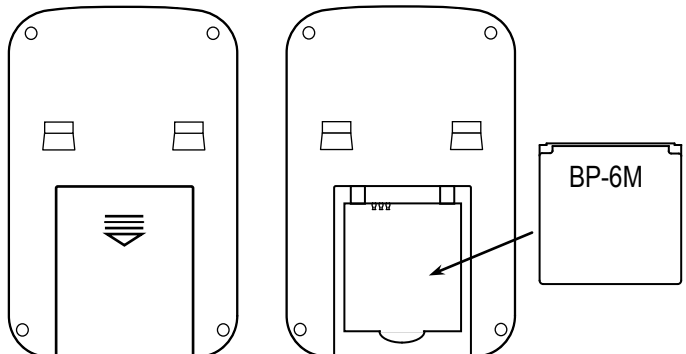

Installation – Monitor (continued):

Recharge the monitor battery:

There are two ways to recharge the monitor battery.

1. Place the monitor into the monitor charger stand and plug the charger into the stand.

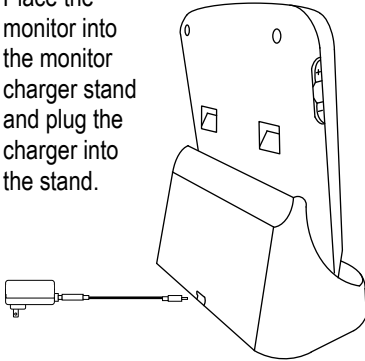

2. Plug the charger directly into the monitor.

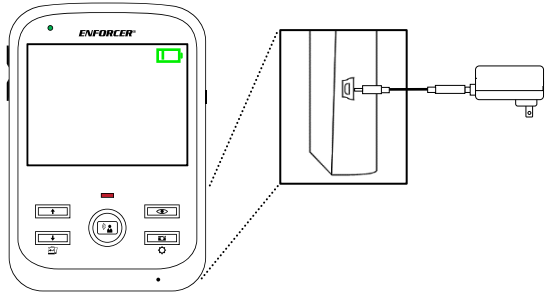

Turn monitor ON:

Hold the “ON/OFF” button for 3 seconds. The monitor will turn ON with the ENFORCER screen.

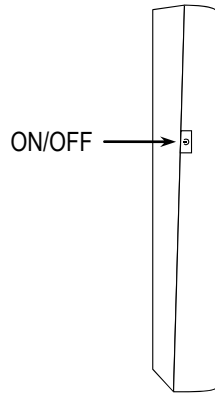

Standby mode:

If the monitor is on, press the “ON/OFF” button momentarily to go to standby mode (if the display is ON) or to leave standby mode (if the display is OFF).

The red indicator LED will flash once every three seconds in standby mode.

Battery saver:

If the display is ON and there is no user action for 35 seconds, the display will turn OFF and the monitor will go into standby mode.

Low battery:

When the battery is low (indicated by 1 or 0 bars on the display's battery icon), the red indicator LED will start to flash once per second.

Turn monitor OFF:

While the monitor's display is ON, hold the “ON/OFF” button for 3 seconds and the monitor will turn OFF.

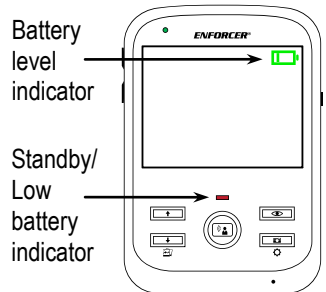

Programming:

1. While the monitor display is on, hold the “Photo/Settings” button for 3 seconds to enter programming mode.
2. Press the “Photo/Settings” button to cycle through the programming options, including:
 - a. Time setup
 - b. Ringtone choice
 - c. Lock delay
 - d. PIR setup
3. To exit programming mode, press the “Photo/Settings” button to cycle through the remaining programming modes, or press the “Talk” button to return to the home screen.
NOTE: If there is no activity, the monitor will exit programming mode and the display will turn off in 35 seconds.

Programming the display time:

1. Hold the “Photo/Settings” button for 3 seconds to enter programming mode.
2. Use the up and down arrow buttons on the front of the monitor to highlight the area to be changed.
3. Use the volume buttons (+/-) to adjust the time or date.
4. Press the “Talk” button to set the display time and exit programming mode.

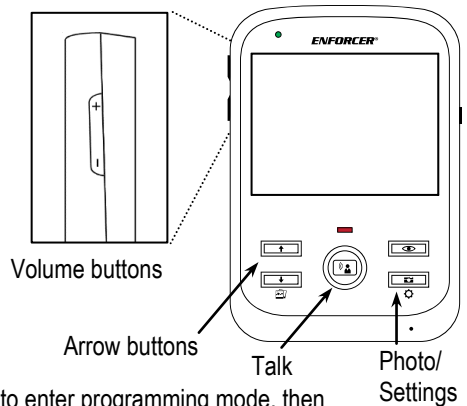

Programming the ringtones:

1. Hold the “Photo/Settings” button for 3 seconds to enter programming mode, then momentarily press the “Photo/Settings” button one time to select the ringtone display.
2. Use the up and down arrow buttons on the front of the monitor to choose one of 4 ringtones: Telephone, Doorbell, “Für Elise”, or “Jingle Bells”. This is the tone the user will hear when a visitor requests entry.
3. Use the volume buttons (+/-) to adjust the volume of the ringtone.
4. Press the “Talk” button to set the ringtone and exit programming mode.

Programming the lock delay:

This determines how long the relay output is active after the door has been unlocked.

1. Hold the “Photo/Settings” button for 3 seconds to enter programming mode, then momentarily press the “Photo/Settings” button two times to select the lock delay.
2. Use the up and down arrow buttons on the front of the monitor to set the lock delay from 1 to 6 seconds. The default setting is 1 second.
3. Press the “Talk” button to set the lock delay and exit programming mode.

Programming the PIR sensor ON/OFF:

The camera has a built-in PIR (passive infrared) sensor to detect an approaching visitor and automatically turns the camera on and captures a photo. It can be programmed ON or OFF.

1. Hold the “Photo/Settings” button for 3 seconds to enter programming mode, then briefly press the “Photo/Settings” button three times to select the PIR mode.
2. Use the up and down arrow buttons on the front of the monitor to turn the PIR sensor ON or OFF.
3. Press the “Talk” button to set the PIR sensor and exit programming mode.

Operating the Wireless Video Door Phone:

Request entry:

1. Press the doorbell button on the camera.
2. Wait for someone to press the "ON/OFF" button on the monitor to unlock the door.

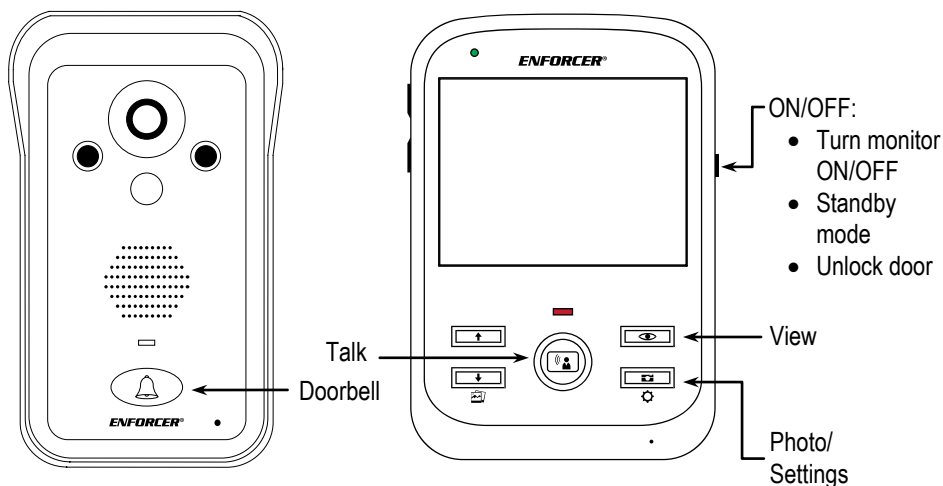

Receive a visitor:

1. If a visitor presses the doorbell button on the camera, the monitor's display turns ON and the monitor sounds the chosen ring tone.
2. To talk with the visitor, press the "Talk" button.
3. To unlock the optional electronic door lock, press the "ON/OFF" button briefly while the monitor is displaying the camera's view.
4. Press the "Talk" button again to turn off the monitor.

View and/or talk to a visitor who has not pressed the doorbell button on the camera:

1. Press the "ON/OFF" button to turn the monitor's display ON.
2. Press the monitor's "View" button to turn the camera on. At this time, the monitor can hear sound and view video from the camera.
3. Press the monitor's "Talk" button to enable communication between the monitor and camera.
4. To unlock the optional electronic door lock, press the "ON/OFF" button momentarily while the monitor is displaying the camera's view.

NOTE: The "Talk" button must be pressed before pressing the "ON/OFF" button. Otherwise pressing the "ON/OFF" button will turn off the monitor.

5. Press the monitor's "View" button to mute the monitor or "Talk" button to end monitoring of the camera.

Manually take a photo:

1. While the monitor is displaying the camera's view, press the "Photo/Settings" button to manually take a photo.
2. If the user does not answer a call within 5 seconds, the camera will take a photo automatically.

NOTE: If the monitor's battery is low, the photo-taking function will not work.

Operating the Wireless Video Door Phone (continued):

Adjust the monitor's color tint:

1. Press the "ON/OFF" button to turn the monitor's display ON.
2. Press the monitor's "View" button to turn the camera on.
3. While the camera's image is displayed, press the up and down arrows on the front of the monitor to turn the brightness up and down.
4. Press the monitor's "View" button to save the brightness setting and turn the camera off.

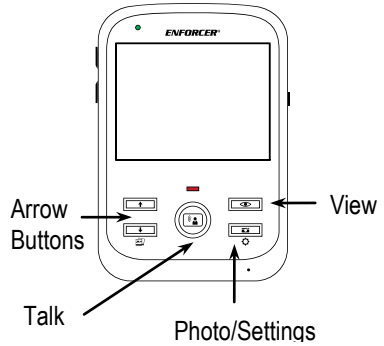

Access the photo gallery:

1. The monitor can be used to view up to 100 photos that have been captured by the camera, and to delete photos no longer needed.
2. Press the "ON/OFF" button to turn the monitor's display ON.
3. Press and hold the down arrow on the front of the monitor 3 seconds until the letter "P" and the number of stored photos show on the top of the screen.
4. Press the up and down arrows on the front of the monitor to view the captured photos.
5. To delete a photo:
 - a. Press the "Photo/Settings" button.
 - b. Press the up and down arrows on the front of the monitor to select "Y" (yes, delete), "N" (no, do not delete), or "ALL" (delete all photos).
 - c. Press the "Talk" button to select. If "Y" is selected, the photo will be deleted.

NOTE: Monitor will automatically delete the oldest photo when full.

NOTE: It is not possible to export internal photos.

Pairing Additional Monitors:

NOTE: By default, the monitor in the **DP-236Q** Complete Kit is paired with the camera. These instructions apply to pairing a second or third monitor.

To pair a monitor with the camera:

1. Disable the tamper alarm:
 - a. Remove the camera from the bracket.
 - b. The tamper alarm will now sound. Press the "Talk" button on the already-paired monitor repeatedly to disable the tamper alarm.
2. Pair the new monitor to the camera:
 - a. Turn on the monitor to be paired by holding the "ON/OFF" button for three seconds.
 - b. Quickly press the "ON/OFF" button three times. The screen will display "Pairing" for about 15 seconds. The monitor will allow pairing only once per bootup, so you may need to power it OFF and ON again if the attempt fails.
3. Pair the camera to the new monitor:
 - a. While the monitor displays "Pairing", use a paperclip or other small object to press the camera's reset button twice.
 - b. Two or three beeps confirm the pairing of the second or third monitor respectively.
4. Return the camera to the bracket:
 - a. Mount the camera in the bracket.
 - b. Press the doorbell button on the camera to test the connection.

Resetting the Camera and Pairing a First Monitor:

To reset the camera and pair a first monitor:

1. Clear the camera's existing pairings:
 - a. Remove the camera from the bracket.
 - b. The alarm will begin to sound.
 - c. Remove the battery from the camera then replace the battery to deactivate the tamper alarm.
 - d. Use a paper clip or other small object to press and hold the camera's reset button for three seconds. A beep confirms the pairings have been cleared.
 2. Pair the monitor to the camera:
 - a. Turn on the monitor by holding the "ON/OFF" button for three seconds.
 - b. Quickly press the "ON/OFF" button three times. The screen will display "Pairing" for about 15 seconds. The monitor will allow pairing only once per bootup, so you may need to power it OFF and ON again if the attempt fails.
 3. Pair the camera to the monitor:
 - a. While the monitor displays "Pairing", press the camera's reset button twice.
 4. One beep confirms the pairing of the first monitor. Return the camera to the bracket:
 - a. Mount the camera in the bracket.
 - b. Press the doorbell button on the camera to test the connection.
-

Tamper Alarm:

The camera's tamper alarm will sound when the camera is removed from its bracket, warning the homeowner of possible vandalism. Only the first programmed monitor will sound an alarm.

NOTE: If the camera is removed and replaced within 2 seconds, the camera will instead send a warning call to the monitor. Answer the call as normal by pressing the "Talk" button, and then again to hang up the call.

1. To disable the tamper alarm if no monitors are paired with the camera:
 - a. Return the camera to the bracket.
 - b. If the alarm persists, unplug the camera and remove the battery.
 - c. Return the camera's battery and reconnect it to power.
2. To disable the tamper alarm if one or more monitors are paired with the camera:
 - a. Repeatedly press the "Talk" button on one of the paired monitors to disable the tamper alarm.
 - b. If the alarm persists, unplug the camera and remove the battery.
 - c. Unplug each monitor and remove each monitor's battery.
 - d. Return the camera's battery and reconnect it to power.
 - e. Insert each monitor's battery and reconnect each monitor to power.

Troubleshooting:

The monitor's screen is blank.

- Make sure the "ON/OFF" button was pressed.
- Recharge the monitor's battery.
- Plug the charger directly into the monitor.

The monitor does not ring.

- Check that the volume is turned up.
- Check that the monitor is in standby mode.
- Check that the monitor is placed in the mounting bracket.

The monitor's screen turns on, but does not display the camera's image.

- Check that the monitor has been paired with the camera.
- Check that the monitor is within range of the camera.

The monitor's screen image quality is poor.

- Adjust the monitor's display brightness (see Operating the Wireless Video Door Phone on pg. 9~10).
- Clean the camera's lens using a soft, clean cloth.
- Change the position of the camera.
- Move the monitor away from microwaves, television, lamps, and other potential sources of electromagnetic interference.

The monitor's "ON/OFF" button does not unlock the door's optional locking device.

- Check the wiring between the camera and the optional door locking device.
- Check that the unit is in two-way communication.

IMPORTANT: Users and installers of this product are responsible for ensuring this product complies with all national, state, and local laws and statutes related to monitoring and recording audio and video signals. SECO-LARM will not be held responsible for the use of this product in violation of any current laws or statutes.

WARNING: Stop using the camera if you see a malfunction such as smoke or unusual heat, as it could cause fire or electric shock. Do not open the case of this device, as there are no field-serviceable components inside.

FCC COMPLIANCE STATEMENT:

DP-236-CQ FCC ID:K4E236CQ

DP-236-MQ FCC ID:K4E236MQ

THIS DEVICE COMPLIES WITH PART 15 OF THE FCC RULES. OPERATION IS SUBJECT TO THE FOLLOWING TWO CONDITIONS: (1) THIS DEVICE MAY NOT CAUSE HARMFUL INTERFERENCE AND (2) THIS DEVICE MUST ACCEPT ANY INTERFERENCE RECEIVED, INCLUDING INTERFERENCE THAT MAY CAUSE UNDESIRE OPERATION.

Notice: The changes or modifications not expressly approved by the party responsible for compliance could void the user's authority to operate the equipment.

IMPORTANT NOTE: To comply with the FCC RF exposure compliance requirements, no change to the antenna or the device is permitted. Any change to the antenna or the device could result in the device exceeding the RF exposure requirements and void user's authority to operate the device.

WARRANTY: This SECO-LARM product is warranted against defects in material and workmanship while used in normal service for a period of one (1) year from the date of sale to the original customer. SECO-LARM's obligation is limited to the repair or replacement of any defective part if the unit is returned, transportation prepaid, to SECO-LARM.

This Warranty is void if damage is caused by or attributed to acts of God, physical or electrical misuse or abuse, neglect, repair or alteration, improper or abnormal usage, or faulty installation, or if for any other reason SECO-LARM determines that such equipment is not operating properly as a result of causes other than defects in material and workmanship.

The sole obligation of SECO-LARM, and the purchaser's exclusive remedy, shall be limited to replacement or repair only, at SECO-LARM's option. In no event shall SECO-LARM be liable for any special, collateral, incidental, or consequential personal or property damages of any kind to the purchaser or anyone else.

NOTICE: The information and specifications printed in this manual are current at the time of publication. However, the SECO-LARM policy is one of continual development and improvement. For this reason, SECO-LARM reserves the right to change specifications without notice. SECO-LARM is also not responsible for misprints or typographical errors.

Copyright © 2015 SECO-LARM U.S.A., Inc. All rights reserved. This material may not be reproduced or copied, in whole or in part, without the written permission of SECO-LARM.

SECO-LARM® U.S.A., Inc.

16842 Millikan Avenue, Irvine, CA 92606

Tel: 800-662-0800 / 949-261-2999 Fax: 949-261-7326

Website: www.seco-larm.com

E-mail: sales@seco-larm.com



MIDP-236Q_150528.docx