

## Specifications:

Sensing range	0.5' to 33' (0.1 - 10 m)		
Voltage supply	12-250 VAC/DC		
Current drain (max.)		Stand by	Active
	12 VDC	20 mA	40 mA
	24 VDC	10 mA	20 mA
Response time	10 ms (max.)		
Tx LED element	Infrared - 740 nm		
LEDs	Green LED (Alignment), Red LED (trigger)		
Trigger output	SPDT relay output, 1 A @ 125 VAC, 2 A @ 30 VDC		
Tamper switch	N.C., 500 mA @ 30 VAC		
Enclosure	IP 66 weatherproof		
Ambient temperature	-4 <sup>o</sup> -131 <sup>o</sup> F (-20 <sup>o</sup> -55 <sup>o</sup> C)		

## Also available from SECO-LARM:

Quad and Twin  
Photobeam Detectors  
Up to 660' (200 m)



E-964-Q660Q  
(Shown)

Flush-Mount  
Photobeam Sensors  
Up to 33' (10 m)

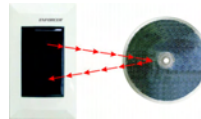

E-932-D33TBQ

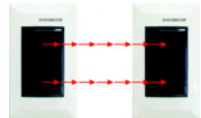

E-932-S16RRQ

Entry Alert System  
Photobeam Sensors  
Up to 22' (7 m)

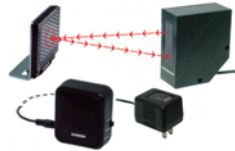

E-931CS2RRCQ

# ENFORCER<sup>®</sup> Sensor

## Polarized Retro-Reflective Photoelectric Sensor

### E-931-S33PRQ

Range: 33 ft. (10 m)



# INSTALLATION MANUAL

## Features:

- Polarized sensor is immune to shiny objects: Triggers only when correctly reflected light is detected.
- Weatherproof (IP 66) design with cable gasket for indoor/outdoor use.
- Anti-condensation case.
- Dark ON operation.
- Round reflector, Dia.: 80 mm.
- Input volt.: 12-250 VDC/VAC.
- Form "C" relay, 2A @ 30 VDC.
- LED alignment system.
- Tamper switch: N.C. 500 mA @ 30 VDC.

## Typical Applications:

- Safety sensor for garage doors, outdoor gates, or sliding doors.
- Overhead door security sensor.
- Industrial automation — Detect small objects on a manufacturing line.
- Assist in measuring parking distance.
- Alarm sensor for windows, terraces, parking lot, etc.

## Includes:

- Reflector
- Sensor
- Sensor mounting plate
- Weather-resistant gasket
- Sensor hood

## Dimensions:

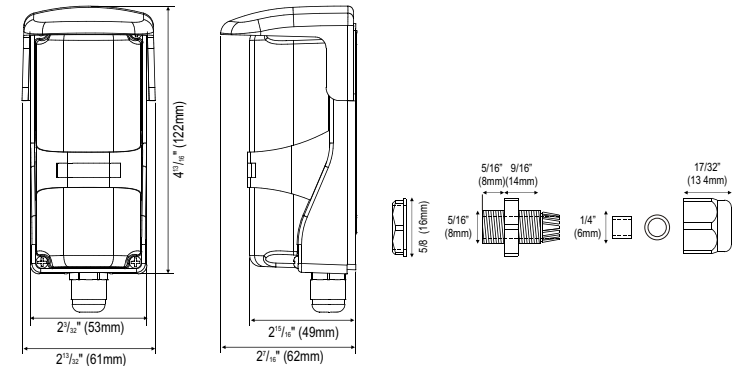

## Caution:

- This sensor was not designed to prevent bodily injury or loss of life.
- Use of this sensor in certain security applications may be regulated by local laws or codes.
- This sensor was not designed for use in environments where there is the possibility of explosive gasses present.
- SECO-LARM is not responsible for compliance with such laws or codes.

**WARRANTY** This SECO-LARM product is warranted against defects in material and workmanship while used in normal service for a period of one (1) year from the date of sale to the original consumer customer. SECO-LARM's obligation is limited to the repair or replacement of any defective part if the unit is returned, transportation prepaid, to SECO-LARM.

This Warranty is void if damage is caused by or attributed to acts of God, physical or electrical misuse or abuse, neglect, repair, or alteration, improper or abnormal usage, or faulty installation, or if for any other reason SECO-LARM determines that such equipment is not operating properly as a result of causes other than defects in material and workmanship.

The sole obligation of SECO-LARM, and the purchaser's exclusive remedy, shall be limited to replacement or repair only, at SECO-LARM's option. In no event shall SECO-LARM be liable for any special, collateral, incidental, or consequential personal or property damages of any kind to the purchaser or anyone else.

**NOTICE:** The information and specifications printed in this manual are current at the time of publication. However, the SECO-LARM policy is one of continual development and improvement. For this reason, SECO-LARM reserves the right to change specifications without notice. SECO-LARM is also not responsible for misprints or typographical errors.

Copyright © 2010 SECO-LARM U.S.A., Inc. All rights reserved. This material may not be reproduced or copied, in whole or in part, without the written permission of SECO-LARM.

## SECO-LARM<sup>®</sup> U.S.A., Inc.

16842 Millikan Avenue, Irvine, CA 92606

Tel: 800-662-0800 / 949-261-2999 Fax: 949-261-7326

Website: [www.seco-larm.com](http://www.seco-larm.com)

E-mail: [info@seco-larm.com](mailto:info@seco-larm.com)

PITSW3  
MIE931-S33PROQ\_1012.PMD

## Sample Installations:

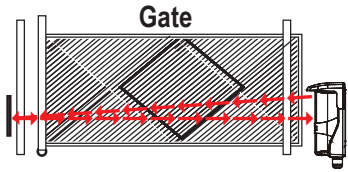

Vehicle detection

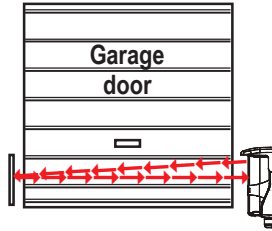
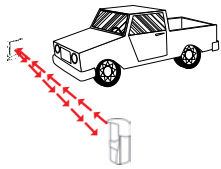

Factory assembly line

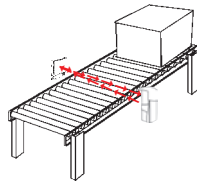

## Wiring:

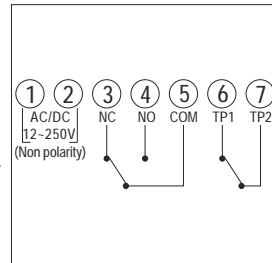
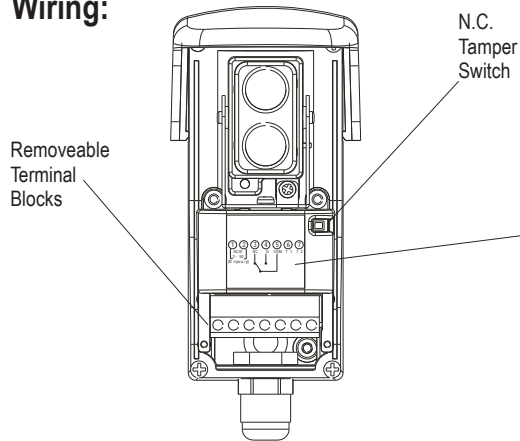

Additional function:  
TP1/TP2 - Tamper Switch:  
N.C. 500 mA @ 30 VDC

## Mounting the Sensor:

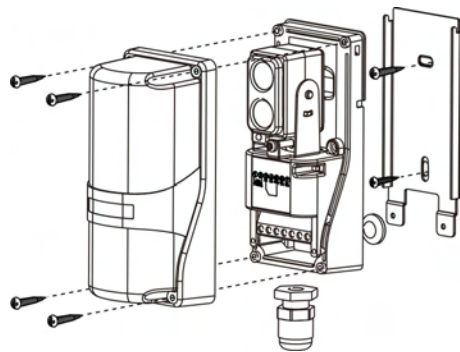

1. Unscrew the 4 screws and remove the cover.
2. Loosen the captive screw to free the sensor from the mounting plate.
3. Using the included screws, mount the mounting plate to the wall.
4. If the wires come from inside the wall, use the breakout and rubber gasket on the back of the sensor to run the wires. If not, use the breakout and cable gland at the bottom of the sensor to run the wires.
5. Remove the terminal block using long-nose pliers and wire the unit according to the wiring diagram above.
6. Hang the sensor back on to the plate, and use the captive screw to secure it in place.
7. Re-attach the cover, and use the included small screws to secure it.
8. Attach the hood to the top of the sensor.

## Installation and Adjustment:

### Dual-Color LED Functions:

- Red LED – When ON, it indicates the sensor is triggered.
- Green LED – When ON, it indicates that the sensor is properly aligned with the reflector, and the sensor is not triggered.
- LED alternately flashes red and green – Sensor beam signal is weak (not triggered).

### Installation:

1. Mount the reflector and the sensor so they face each other.
2. Connect power to the sensor. Typically the red LED will turn ON indicating that the sensor and reflector are not yet properly aligned. If the Green LED is ON (red LED OFF), it indicates that the sensor and reflector are aligned (although it still may be necessary to slightly adjust the alignment).
3. To find the correct alignment, slowly turn the lens

assembly left and right, and use the vertical adjustment screw to tilt the sensor up and down.

**NOTE 1:** Correct alignment is reached when the red LED turns OFF and the Green LED turns ON.

**NOTE 2:** If the LED alternately flashes green and red, the sensor is at the edge of sensing the signal, and may not work properly.

4. Put the object to be detected between the sensor and reflector (in about the place where the object would normally be detected by the sensor). The green LED should turn OFF and the red LED will turn ON).

### Testing:

1. Power up the sensor. The green LED should be ON; the red LED should be OFF.
2. Pass the object to be detected between the sensor and reflector. The red LED should turn ON and the green LED should turn OFF. This indicates that the object has been detected.

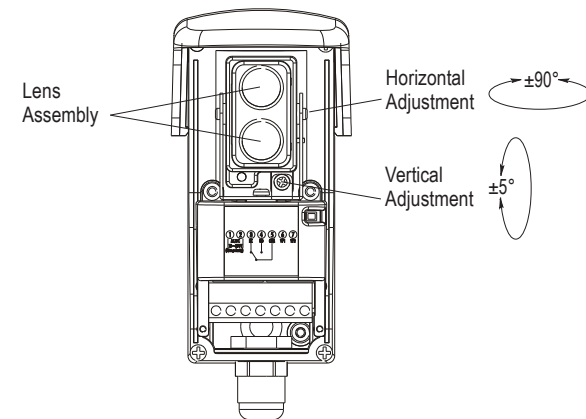

## Troubleshooting:

Trouble	Possible Origin(s)	Remedy(s)
Sensor does not detect the object.	1) Sensor sensitivity is not properly set. 2) Object may have a reflective surface which confuses sensor.	Change the angle of the sensor or readjust the sensitivity setting.
Green LED does not turn on.	1) Dirty sensor and/or reflector. 2) Reflector and/or sensor is misaligned.	1) Clean the sensor and reflector with a damp (not wet) cloth. 2) Adjust the reflector and/or sensor for proper alignment.
Red LED lights when object is detected, but no output.	No continuity between sensor and alarm device.	Check cable from sensor to alarm device. Test sensor.