

ENFORCER®

Video Amplifiers Manual



VA-2101B-WQ
VA-2101B-WAQ*
1-In, 1-Out



VA-2404B-WQ
VA-2404B-WAQ*
4-In, 4-Out

- Compatible with both color and B/W signals
- Transmission distance up to 3,280ft (1,000m)
- Connect to a video camera, multiplexer, DVR, etc.

- Gold-plated BNC connectors
- Sharpness and brightness adjustments for each channel
- 12VDC Power adapter included
- Pass-through circuit: Power output can power nearby devices

*VA-2101B-WAQ and VA-2404B-WAQ do not include a power adapter.

Introduction:

ENFORCER Video Amplifiers are the idea way to boost the strength of video signals. Using the included 12VDC power adapter, video signals are amplified for transmission distances of up to 3,280ft (1,000m). Brightness and sharpness adjustments can be made independently for each channel to provide fine-tuning of video signals.

Specifications:

	VA-2101B-WQ	VA-2101B-WAQ	VA-2404B-WQ	VA-2404B-WAQ
Number of inputs	1		4	
Number of outputs	1		4	
Maximum range	3,280' (1,000m)			
Video input level	0.8~1.2 Vp-p, 75Ω			
Video output level	1 Vp-p, 75Ω			
Video bandwidth	10 Hz~10MHz			
Power supply(12VDC)	Included	Not included	Included	Not included
Current consumption	100mA		220mA	
Dimensions	4 ¹⁵ / ₁₆ " x 4 ¹ / ₈ " x 1 ³ / ₈ " (125 x 104 x 35 mm)			
Weight	4.1 oz (116g)		6.3 oz. (179g)	

Dimensions:

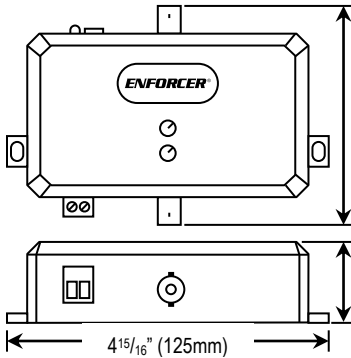

VA-2101B-WQ
VA-2101B-WAQ

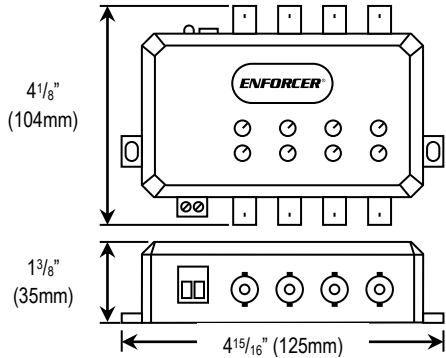

VA-2404B-WQ
VA-2404B-WAQ

Overview:

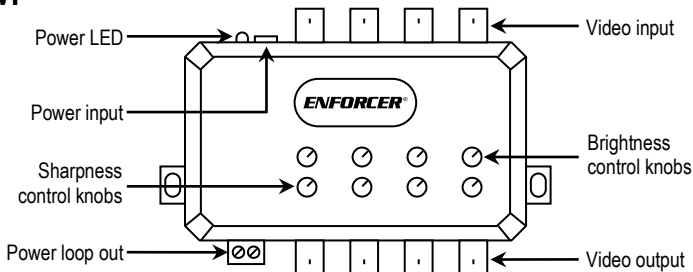

Installation:

1. Mount and install the amplifier where the video inputs and outputs can be easily accessed.
2. Connect the video output of each camera to the female BNC input connector(s) on the amplifier.
3. Connect coax cable from the female output BNC connector(s) to the DVR or display.
4. Connect power to the distributor with the included 12VDC power adapter.
5. Turn on power to the video input and the video output units the amplifier is connected to.

Note: Total distance between the camera and DVR/monitor should not exceed 3,280ft (1,000m).

Sample Application (VA-2404B-WQ / VA-2404B-WAQ):

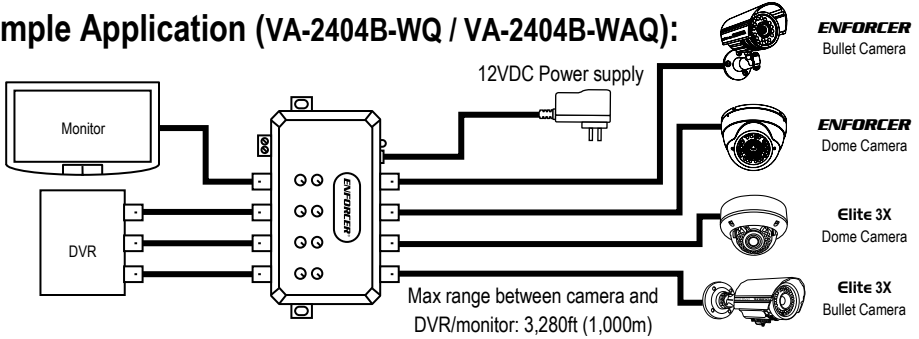

Sample Application (VA-2101B-WQ / VA-2101B-WAQ):

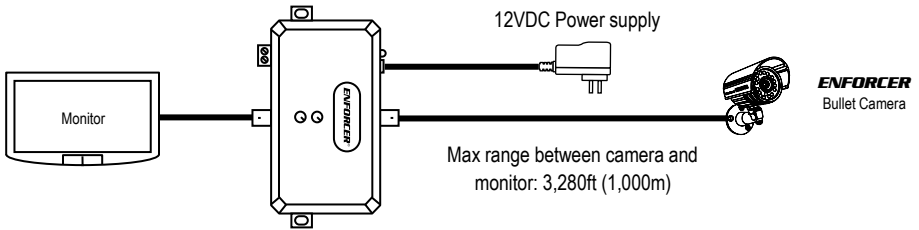

Brightness and Sharpness

Adjustments:

ENFORCER Video Amplifiers have sharpness and brightness adjustments for each channel. Turn the knobs with a small screwdriver clockwise to increase sharpness or brightness values, or counterclockwise to decrease them.

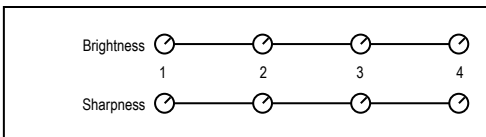

Power Loop Out:

ENFORCER Video Amplifiers have the ability to power other 12VDC devices. Connect other devices to the power loop out terminal blocks.

NOTE: The current draw of the video amplifiers will lower the amount of voltage present at the power loop out. To ensure proper operation of the connected devices, first check the voltage present at the terminal blocks.

Troubleshooting:

Video amplifier does not function correctly:

- Make sure the power, input, and output cables are connected firmly to the amplifier.
- Make sure the video input device is turned on.
- Make sure the video output device is turned on.
- Test the coaxial cable between the video input and the amplifier to make sure it is functional.
- Test the coaxial cable between the video output and the amplifier to make sure it is functional.

Power LED indicator not lit:

- Make sure power is connected to the amplifier.

Also Available from SECO-LARM:

Passive VGA Balun



MVE-SV010Q

Elite Passive Video Balun



EB-P501-01Q

BNC-to-VGA Converter



VC-1BAQ

SECO-LARM® has a complete line of security products.

Please visit www.seco-larm.com for more information.

WARRANTY: This SECO-LARM product is warranted against defects in material and workmanship while used in normal service for a period of one (1) year from the date of sale to the original consumer customer. SECO-LARM's obligation is limited to the repair or replacement of any defective part if the unit is returned, transportation prepaid, to SECO-LARM. This Warranty is void if damage is caused by or attributed to acts of God, physical or electrical misuse or abuse, neglect, repair, or alteration, improper or abnormal usage, or faulty installation, or if for any other reason SECO-LARM determines that such equipment is not operating properly as a result of causes other than defects in material and workmanship. The sole obligation of SECO-LARM, and the purchaser's exclusive remedy, shall be limited to replacement or repair only, at SECO-LARM's option. In no event shall SECO-LARM be liable for any special, collateral, incidental, or consequential personal or property damages of any kind to the purchaser or anyone else.

NOTICE: The information and specifications printed in this manual are current at the time of publication. However, the SECO-LARM policy is one of continual development and improvement. For this reason, SECO-LARM reserves the right to change specifications without notice. SECO-LARM is also not responsible for misprints or typographical errors.

Copyright © 2013 SECO-LARM U.S.A., Inc. All rights reserved. This material may not be reproduced or copied, in whole or in part, without the written permission of SECO-LARM.

SECO-LARM® U.S.A., Inc.

16842 Millikan Avenue, Irvine Ca 92606

Tel: 800-662-0800 / 949-261-2999

Fax: 949-261-7326

Website: www.seco-larm.com

Email: sales@seco-larm.com

 PITSW4
MiVA-2xxxB-xQ_1307B.docx